

Technical Information

Proline Promass 840

Coriolis flowmeter



The robust high-pressure flowmeter with custody transfer functionality

Application

- Measuring principle operates independently of physical fluid properties such as viscosity or density
- For premium accuracy and highest process pressures; fully suitable for offshore conditions

Device properties

- Measuring tube in 25Cr Duplex, 1.4410 (UNS S32750)
- Process pressure up to PN 250, Class 1500
- Nominal diameter: DN 80 to 150 (3 to 6")
- 4-line backlit display with touch control
- Device in compact or remote version
- Phase-shifted pulse, HART, Modbus RS485

Your benefits

- Maximum safety – highest resistance to stress corrosion cracking
- Fewer process measuring points – multivariable measurement (flow, density, temperature)
- Space-saving installation – no in/outlet run needs
- Quality – designed for custody transfer; featuring worldwide recognized metrological approvals
- Flexible data transfer options – numerous communication types
- Automatic recovery of data for servicing

Table of contents

Function and system design	3	Process	16
Measuring principle	3	Medium temperature range	16
Measuring system	4	Fluid density range	16
Input	4	Medium pressure range (nominal pressure)	16
Measured variable	4	Pressure-temperature ratings	17
Measuring range	4	Rupture disk	18
Measuring range in custody transfer mode		Limiting flow	18
MI-005 Evaluation Certificate	5	Pressure loss	18
Operable flow range	5	System pressure	18
Input signal	5	Heating	18
Output	6	Custody transfer measurement	19
Output signal	6	Custody transfer variables	19
Signal on alarm	6	Suitability for custody transfer, metrological control, obligation	
Load	6	to subsequent verification	19
Low flow cutoff	6	Verification (Example)	19
Galvanic isolation	6	Stamp points	20
Switching output	6	Mechanical construction	21
Power supply	7	Design, dimensions	21
Terminal assignment	7	Weight	30
Supply voltage	7	Material	31
Power consumption	7	Process connections	31
Power supply failure	7	Operability	31
Electrical connection	8	Local operation	31
Electrical connection Remote version	8	Language group	32
Potential equalization	9	Remote operation	32
Cable entries	9	Certificates and approvals	32
Remote version cable specification	9	CE mark	32
Performance characteristics	9	C-Tick symbol	32
Reference operating conditions	9	Ex approval	32
Maximum measured error	9	Modbus certification	32
Repeatability	10	Pressure equipment directive	32
Response time	11	Measuring Instruments Directive	33
Influence of medium temperature	11	Suitability for custody transfer measurement	33
Influence of medium pressure	11	Approval for custody transfer	33
Design fundamentals	11	Other standards and guidelines	34
Installation	13	Ordering Information	34
Mounting location	13	Accessories	34
Orientation	14	Device-specific accessories	34
Installation instructions	14	Communication-specific accessories	35
Inlet and outlet runs	14	Service-specific accessories	35
Length of connecting cable	15	System components	35
Special installation instructions	15	Documentation	36
Environment	16	Registered trademarks	36
Ambient temperature range	16		
Storage temperature	16		
Degree of protection	16		
Shock resistance	16		
Vibration resistance	16		
Electromagnetic compatibility (EMC)	16		

Function and system design

Measuring principle

The measuring principle is based on the controlled generation of Coriolis forces. These forces are always present when both translational and rotational movements are superimposed.

$$F_C = 2 \cdot \Delta m (v \cdot \omega)$$

F_C = Coriolis force

Δm = moving mass

ω = rotational velocity

v = velocity of the moving mass in a rotating or oscillating system

The amplitude of the Coriolis force depends on the moving mass Δm , its velocity v in the system, and thus on the mass flow. Instead of a constant angular velocity ω , the Promass sensor uses oscillation.

The measuring tubes through which the measured material flows are brought into oscillation. The Coriolis forces produced at the measuring tubes cause a phase shift in the tube oscillations (see illustration):

- At zero flow, in other words when the fluid is at a standstill, the two tubes oscillate in phase (1).
- Mass flow causes deceleration of the oscillation at the inlet of the tubes (2) and acceleration at the outlet (3).

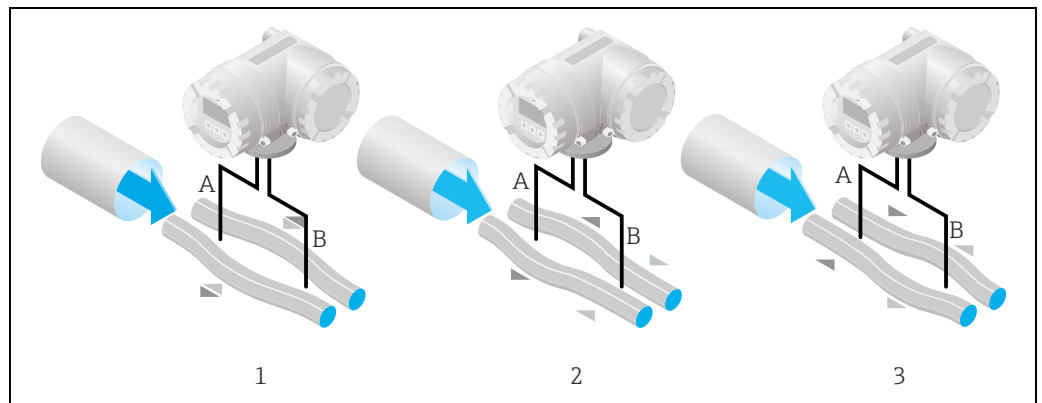

The phase difference (A-B) increases with increasing mass flow. Electrodynamic sensors register the tube oscillations at the inlet and outlet.

System balance is ensured by the antiphase oscillation of the two measuring tubes. The measuring principle operates independently of temperature, pressure, viscosity, conductivity and flow profile.

Density measurement

The measuring tubes are continuously excited at their resonance frequency. A change in the mass and thus the density of the oscillating system (comprising measuring tubes and fluid) results in a corresponding, automatic adjustment in the oscillation frequency. Resonance frequency is thus a function of fluid density. The microprocessor utilizes this relationship to obtain a density signal.

Temperature measurement

The temperature of the measuring tubes is determined in order to calculate the compensation factor due to temperature effects. This signal corresponds to the process temperature and is also available as an output.

Measuring system

The measuring system consists of a transmitter and a sensor. Two versions are available:

- Compact version: transmitter and sensor form a mechanical unit.
- Remote version: transmitter and sensor are mounted physically separate from one another.

Transmitter

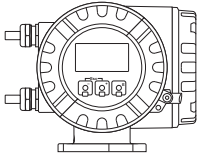
<p>Promass 84</p>  <p style="text-align: right; font-size: small;">a0003672</p>	<ul style="list-style-type: none"> ■ Four-line liquid-crystal display ■ Operation with "Touch control" ■ Application-specific Quick Setup ■ Mass flow, volume flow, density and temperature measurement as well as calculated variables (e.g. fluid concentrations)
---	---

Sensor Promass O

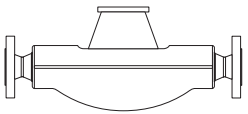
 <p style="text-align: right; font-size: small;">a0003673</p>	<ul style="list-style-type: none"> ■ Universal sensor for fluid temperatures up to +200 °C (+392 °F). ■ Nominal diameters DN 80 to 150 (3 to 6"). ■ Material: <ul style="list-style-type: none"> - Sensor: stainless steel, 1.4404 (316L) - Measuring tube: stainless steel, 25Cr Duplex (Super Duplex), 1.4410 (UNS S32750) - Process connections: stainless steel, 25Cr Duplex (Super Duplex), 1.4410 (UNS S32750)
--	---

Input

Measured variable

- Mass flow (proportional to the phase difference between two sensors mounted on the measuring tube to register a phase shift in the oscillation)
- Fluid density (proportional to resonance frequency of the measuring tube)
- Fluid temperature (measured with temperature sensors)

Measuring range

Measuring ranges for liquids

DN		Range for full scale values (liquids) $\dot{m}_{\min(F)}$ to $\dot{m}_{\max(F)}$	
[mm]	[in]	[kg/h]	[lb/min]
80	3"	0 to 180000	0 to 6615
100	4"	0 to 350000	0 to 12860
150	6"	0 to 800000	0 to 29400

Measuring ranges for gases

The full scale values depend on the density of the gas. Use the formula below to calculate the full scale values:

$$\dot{m}_{\max(G)} = \dot{m}_{\max(F)} \cdot \rho_{(G)} \div x \text{ [kg/m}^3 \text{ (lb/ft}^3\text{)]}$$

$$\dot{m}_{\max(G)} = \text{max. full scale value for gas [kg/h (lb/min)]}$$

$$\dot{m}_{\max(F)} = \text{max. full scale value for liquid [kg/h (lb/min)]}$$

$$\rho_{(G)} = \text{gas density in [kg/m}^3 \text{ (lb/ft}^3\text{)] under process conditions}$$

DN		X
[mm]	[in]	
80	3"	110
100	4"	130
150	6"	200

Here, $\dot{m}_{\max(G)}$ can never be greater than $\dot{m}_{\max(F)}$

Calculation example for gas:

- Sensor type: Promass O, DN 80
- Gas: air with a density of 60.3 kg/m³ (at 20 °C and 50 bar)
- Measuring range (liquid): 180000 kg/h
- x = 130 (for Promass O, DN 80)

Max. possible full scale value:

$$\dot{m}_{\max(G)} = \dot{m}_{\max(F)} \cdot \rho_{(G)} \div x \text{ [kg/m}^3\text{]} = 180000 \text{ kg/h} \cdot 60.3 \text{ kg/m}^3 \div 110 \text{ kg/m}^3 = 98672 \text{ kg/h}$$

Recommended measuring ranges:

See information in the "Limiting flow" Section →  18

Measuring range in custody transfer mode

The following are example data for MI-005 Evaluation Certificate (liquids other than water).

MI-005 Evaluation Certificate

Measuring ranges for liquids in mass flow

DN		Mass flow (liquids) Q _{min} to Q _{max}		Smallest measured quantity	
[mm]	[in]	[t/h]	[tn. sh./h]	[kg]	[lbs]
80	3"	9 to 80	9.92 to 198.42	200	441
100	4"	12 to 270	12.33 to 297.62	200	441
150	6"	15 to 720	16.54 to 793.66	500	1102.5

Measuring ranges for liquids in volume flow

DN		Volume flow Q _{min} to Q _{max}		Smallest measured quantity	
[mm]	[in]	[m ³ /h]	[gal/h]	[l]	[gal]
80	3"	9 to 180	2378 to 47551	200	52.8
100	4"	12 to 270	3170 to 71326	200	52.8
150	6"	15 to 720	3963 to 190200	500	132



Note!

For information about the other approvals → see corresponding certificate.

Operable flow range

Greater than 1000 :1. Flow rates above the preset full scale value do not overload the amplifier, i.e. the totalizer values are registered correctly.

Input signal

Status input (auxiliary input)

U = 3 to 30 V DC, R_i = 5 kΩ, galvanically isolated.

Configurable for: totalizer reset, positive zero return, error message reset, zero point adjustment start, batching start/stop (optional), totalizer reset for batching (optional).

Status input (auxiliary input) with Modbus RS485

U = 3 to 30 V DC, R_i = 3 kΩ, galvanically isolated.

Switch level: ±3 to ±30 V DC, independent of polarity.

Configurable for: totalizer reset, positive zero return, error message reset, zero point adjustment start.

Current input

Active/passive selectable, galvanically isolated, resolution: 2 μA

- Active: 4 to 20 mA, R_L < 700 Ω, U_{out} = 24 V DC, short-circuit proof
- Passive: 0/4 to 20 mA, R_i = 150 Ω, U_{max} = 30 V DC

Output

Output signal	<p>Current output</p> <p>Active/passive selectable, galvanically isolated, time constant selectable (0.05 to 100 s), full scale value selectable, temperature coefficient: typically 0.005% o.r./°C, resolution: 0.5 µA (o.r. = of reading)</p> <ul style="list-style-type: none"> ▪ Active: 0/4 to 20 mA, $R_L < 700 \Omega$ (for HART: $R_L \geq 250 \Omega$) ▪ Passive: 4 to 20 mA; supply voltage U_S 18 to 30 V DC; $R_i \geq 150 \Omega$ <p>Pulse/frequency output</p> <p>active/passive selectable, galvanically isolated</p> <ul style="list-style-type: none"> ▪ Active: 24 V DC, 25 mA (max. 250 mA during 20 ms), $R_L > 100 \Omega$ ▪ Passive: open collector, 30 V DC, 250 mA <ul style="list-style-type: none"> ▪ Frequency output: <ul style="list-style-type: none"> full scale frequency 2 to 10000 Hz ($f_{max} = 12500$ Hz), on/off ratio 1:1, pulse width max. 2 s ▪ Pulse output: <ul style="list-style-type: none"> pulse value and pulse polarity selectable, pulse width configurable (0.05 to 2000 ms) <p>Modbus interface</p> <ul style="list-style-type: none"> ▪ Modbus device type: slave ▪ Address range: 1 to 247 ▪ Supported function codes: 03, 04, 06, 08, 16, 23 ▪ Broadcast: supported with the function codes 06, 16, 23 ▪ Physical interface: RS485 in accordance with EIA/TIA-485 standard ▪ Supported baud rate: 1200, 2400, 4800, 9600, 19200, 38400, 57600, 115200 Baud ▪ Transmission mode: RTU or ASCII ▪ Response times: <ul style="list-style-type: none"> Direct data access = typically 25 to 50 ms Auto-scan buffer (data range) = typically 3 to 5 ms ▪ Possible output combinations →  7
Signal on alarm	<p>Current output</p> <p>Failsafe mode selectable (e.g. in accordance with NAMUR Recommendation NE 43)</p> <p>Pulse/frequency output</p> <p>Failsafe mode selectable</p> <p>Relay output</p> <p>Dead in the event of a fault or if the power supply fails.</p>
Load	see "Output signal"
Low flow cutoff	Switch points for low flow are selectable.
Galvanic isolation	All circuits for inputs, outputs, and power supply are galvanically isolated from each other.
Switching output	<p>Relay output</p> <ul style="list-style-type: none"> ▪ Max. 30 V / 0.5 A AC; 60 V / 0.1 A DC ▪ Galvanically isolated ▪ Normally closed (NC or break) or normally open (NO or make) contacts available (factory setting: relay 1 = NO, relay 2 = NC)

Power supply

Terminal assignment

The inputs and outputs on the communication board can be either permanently assigned (fixed) or variable (flexible), depending on the version ordered (see table). Replacements for modules which are defective or which have to be replaced can be ordered as accessories.

Order characteristic for "inputs/outputs"	Terminal No. (inputs/outputs)			
	20 (+) / 21 (-)	22 (+) / 23 (-)	24 (+) / 25 (-)	26 (+) / 27 (-)
<i>Fixed communication boards (permanent assignment)</i>				
S	-	-	Frequency output Ex i, passive	Current output Ex i Active, HART
T	-	-	Frequency output Ex i, passive	Current output Ex i Passive, HART
<i>Flexible communication boards</i>				
D	Status input	Relay output	Frequency output	Current output, HART
M	Status input	Frequency output 2	Frequency output 1	Current output, HART
N	Current output	Frequency output	Status input	Modbus RS485
Q	-	-	Status input	Modbus RS485
1	Relay output	Frequency output 2	Frequency output 1	Current output 1, HART
2	Relay output	Current output 2	Frequency output	Current output 1, HART
7	Relay output 2	Relay output 1	Status input	Modbus RS485

Supply voltage

85 to 260 V AC, 45 to 65 Hz
 20 to 55 V AC, 45 to 65 Hz
 16 to 62 V DC

Power consumption

AC: <15 VA (including sensor)
 DC: <15 W (including sensor)
Switch-on current:
 ■ Max. 13.5 A (<50 ms) at 24 V DC
 ■ Max. 3 A (<5 ms) at 260 V AC

Power supply failure

Lasting min. 1 power cycle:
 ■ EEPROM and T-DAT save the measuring system data if the power supply fails.
 ■ HistoROM/S-DAT: exchangeable data storage chip with sensor specific data (nominal diameter, serial number, calibration factor, zero point, etc.).

Electrical connection

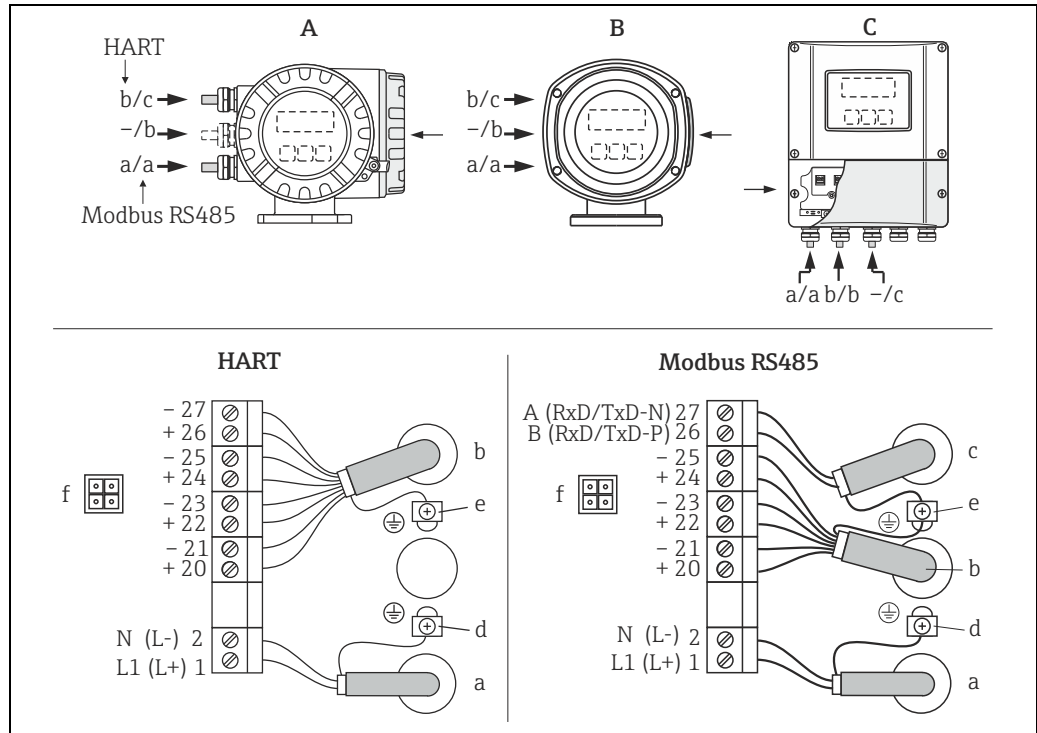

Connecting the transmitter, cable cross-section: max. 2.5 mm²

- A View A (field housing)
- B View B (stainless steel field housing)
- C View C (wall-mount housing)
- a Cable for power supply: 85 to 260 V AC, 20 to 55 V AC, 16 to 62 V DC
- Terminal No. 1: L1 for AC, L+ for DC
- Terminal No 2: N for AC, L- for DC
- b Signal cable: Terminal assignment → 7
- c Fieldbus cable: Terminal assignment → 7
- d Ground terminal for protective earth
- e Ground terminal for Signal cable/Modbus RS485 cable
- f Service connector for connecting service interface FXA 193 with Proline adapter cable (Fieldcheck, FieldCare)

Electrical connection
Remote version

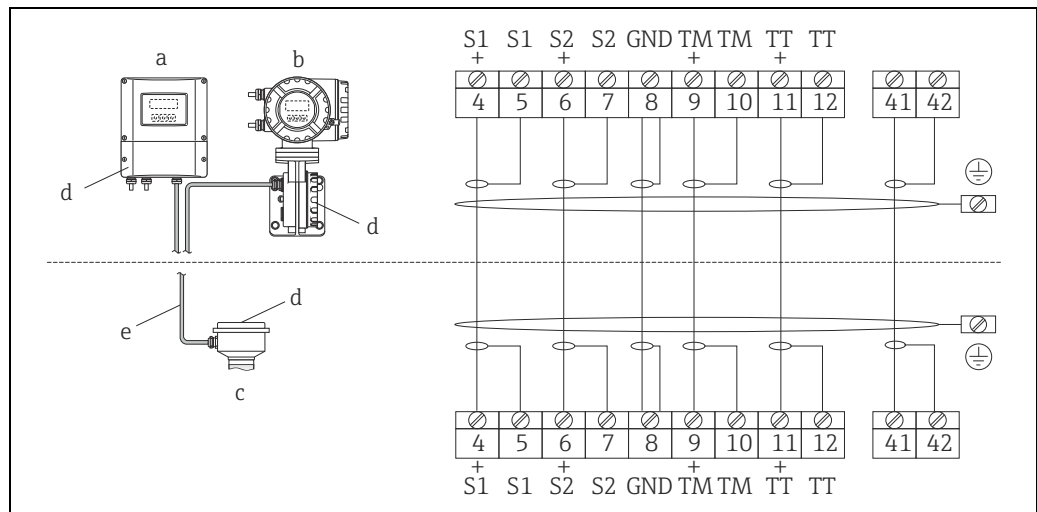

Connecting the remote version

- a Wall-mount housing: non-hazardous area and ATEX II3G / zone 2 → see separate "Ex documentation"
- b Wall-mount housing: ATEX II2G / Zone 1 /FM/CSA → see separate "Ex documentation"
- c Connection housing sensor
- d Cover for connection compartment or connection housing
- e Connecting cable

Terminal No.: 4/5 = gray; 6/7 = green; 8 = yellow; 9/10 = pink; 11/12 = white; 41/42 = brown

Potential equalization No special measures for potential equalization are required. For instruments for use in hazardous areas, observe the corresponding guidelines in the specific Ex documentation.

Cable entries

Power-supply and signal cables (inputs/outputs):

- Cable entry M20 × 1.5 (8 to 12 mm / 0.31" to 0.47")
- Thread for cable entries, ½" NPT, G ½"

Connecting cable for remote version:

- Cable entry M20 × 1.5 (8 to 12 mm / 0.31" to 0.47")
- Thread for cable entries, ½" NPT, G ½"

Remote version cable specification

- 6 × 0.38 mm² (PVC cable with common shield and individually shielded cores)
- Conductor resistance: ≤50 Ω/km (≤0.015 Ω/ft)
- Capacitance: core/shield: ≤420 pF/m (≤128 pF/ft)
- Cable length: max. 20 m (65 ft)
- Permanent operating temperature: max. +105 °C (+221 °F)

Operation in zones of severe electrical interference:

The measuring device complies with the general safety requirements in accordance with EN 61010, the EMC requirements of EN 61326/A1, and NAMUR recommendation NE 21/43.

Performance characteristics

Reference operating conditions

- Error limits following ISO 11631
- Water, typically +15 to +45 °C (+59 to +113 °F); 2 to 6 bar (29 to 87 psi)
- Data according to calibration protocol
- Accuracy based on accredited calibration rigs that are traced to ISO 17025

To obtain measured errors, use the Applicator sizing tool *Applicator*: →  35.

Maximum measured error Design fundamentals →  11

o.r. = of reading; 1 g/cm³ = 1 kg/l; T = fluid temperature

Base accuracy

Mass flow and volume flow (liquids)

- ±0.05% o.r. (PremiumCal for mass flow)
- ±0.10% o.r.

Mass flow (gases)

±0.35% o.r.

Density (liquids)

- Reference conditions: ±0.0005 g/cm³
- Field density calibration: ±0.0005 g/cm³ (valid after field density calibration under process conditions)
- Standard density calibrations: ±0.01 g/cm³ (valid over the entire measuring range of the sensor →  16)
- Special density calibration: ±0.001 g/cm³ (optional, valid range: +5 to +80 °C (+41 to +176 °F) and 0.0 to 2.0 g/cm³)

Temperature

±0.5 °C ± 0.005 · T °C (±1 °F ± 0.003 · (T - 32) °F)

Zero point stability

DN		Zero point stability	
[mm]	[in]	[kg/h]	[lb/min]
80	3"	9.00	0.330
100	4"	14.00	0.514
150	6"	32.00	1.17

Flow values

Flow values as turndown parameter depending on nominal diameter.

SI units

DN	1:1	1:10	1:20	1:50	1:100	1:500
[mm]	[kg/h]	[kg/h]	[kg/h]	[kg/h]	[kg/h]	[kg/h]
80	180000	18000	9000	3600	1800	360.0
100	350000	35000	17500	7000	3500	700.0
150	800000	80000	40000	16000	8000	1600

US units

DN	1:1	1:10	1:20	1:50	1:100	1:500
[in]	[lb/min]	[lb/min]	[lb/min]	[lb/min]	[lb/min]	[lb/min]
3"	6615	661.5	330.8	132.3	66.15	13.23
4"	12860	1286	643.0	257.2	128.6	25.72
6"	29400	2940	1470	588.0	294.0	58.80

Accuracy of outputs

o.r. = of reading; o.f.s. = of full scale value

The output accuracy must be factored into the measured error if analog outputs are used, but can be ignored for fieldbus outputs (e.g. Modbus RS485, EtherNet/IP).

Current output

Accuracy: Max. $\pm 0,05\%$ o.f.s. or $\pm 5\ \mu\text{A}$

Pulse/frequency output

Accuracy: Max. $\pm 50\%$ ppm o.r.

Repeatability

Design fundamentals → 11

o.r. = of reading; $1\ \text{g/cm}^3 = 1\ \text{kg/l}$; T = fluid temperature

Base repeatability**Mass flow and volume flow (liquids)**

- $\pm 0.025\%$ o.r. (PremiumCal for mass flow)
- $\pm 0.05\%$ o.r.

Mass flow (gases)

$\pm 0.25\%$ o.r.

Density (liquids)

$\pm 0.00025\ \text{g/cm}^3$

Temperature

$$\pm 0.25 \text{ }^\circ\text{C} \pm 0.0025 \cdot T \text{ }^\circ\text{C} (\pm 0.45 \text{ }^\circ\text{F} \pm 0.0015 \cdot (T - 32) \text{ }^\circ\text{F})$$

Response time

- The response time depends on the configuration (damping).
- Response time in the event of erratic changes in the measured variable (only mass flow): after 100 ms 95 % of the full scale value.

Influence of medium temperature

When there is a difference between the temperature for zero point adjustment and the process temperature, the typical measured error of the Promass sensor is $\pm 0.0002\%$ of the full scale value/ $^\circ\text{C}$ ($\pm 0.0001\%$ of the full scale value / $^\circ\text{F}$).

Influence of medium pressure

The table below shows the effect on accuracy of mass flow due to a difference between calibration pressure and process pressure.

DN		[% o.r./bar]
[mm]	[in]	
80	3"	-0.0055
100	4"	-0.0035
150	6"	-0.002

Design fundamentals

o.r. = of reading
 BaseAccu = base accuracy in % o.r.
 BaseRepeat = base repeatability in % o.r.
 MeasValue = measured value (in flow units consistent with the zero point stability value \rightarrow 10)
 ZeroPoint = zero point stability

Calculation of the maximum measured error depending on flowrate

Flowrate (in flow units consistent with the zero point stability value \rightarrow 10)	Maximum measured error in % o.r.
$\geq \frac{\text{ZeroPoint}}{\text{BaseAccu}} \cdot 100$ <small>A0021332</small>	$\pm \text{BaseAccu}$ <small>A0021339</small>
$< \frac{\text{ZeroPoint}}{\text{BaseAccu}} \cdot 100$ <small>A0021333</small>	$\pm \frac{\text{ZeroPoint}}{\text{MeasValue}} \cdot 100$ <small>A0021334</small>

Calculation of the repeatability depending on flowrate

Flowrate (in flow units consistent with the zero point stability value \rightarrow 10)	Repeatability in % o.r.
$\geq \frac{1/2 \cdot \text{ZeroPoint}}{\text{BaseRepeat}} \cdot 100$ <small>A0021335</small>	$\pm \text{BaseRepeat}$ <small>A0021340</small>
$< \frac{1/2 \cdot \text{ZeroPoint}}{\text{BaseRepeat}} \cdot 100$ <small>A0021336</small>	$\pm 1/2 \cdot \frac{\text{ZeroPoint}}{\text{MeasValue}} \cdot 100$ <small>A0021337</small>

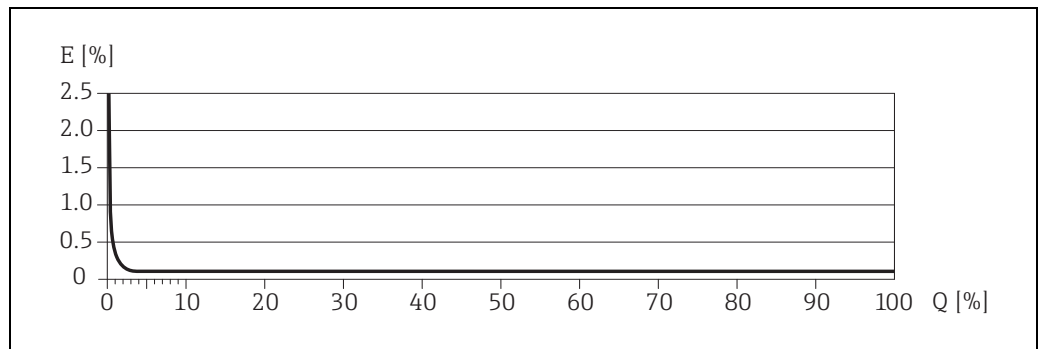
Example for maximum measured error

A0024063

E = Error: Maximum measured error as % o.r.

Q = Flow rate as %

Installation

Mounting location

Entrained air or gas bubbles in the measuring tube can result in an increase in measuring errors. **Avoid** the following mounting locations in the pipe:

- Highest point of a pipeline. Risk of air accumulating.
- Directly upstream from a free pipe outlet in a vertical pipeline

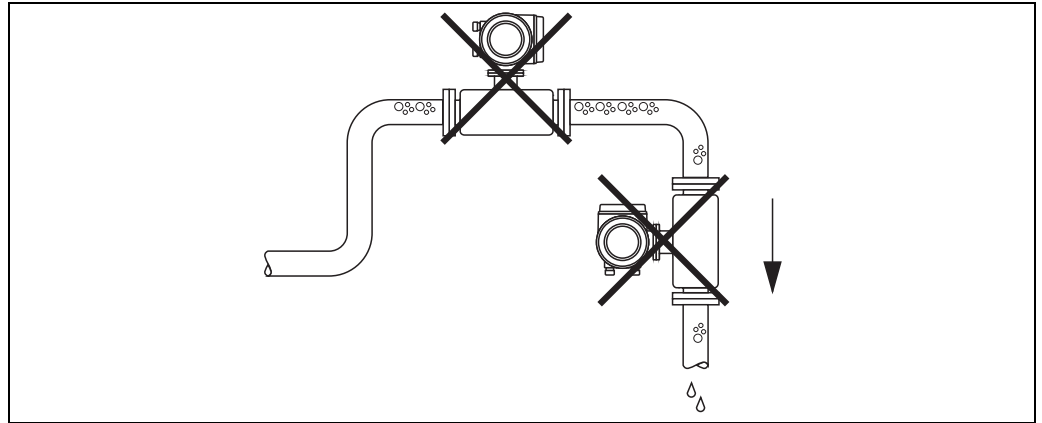

a0003605

Notwithstanding the above, the installation proposal below permits installation in an open vertical pipeline. Pipe restrictions or the use of an orifice with a smaller cross-section than the nominal diameter prevent the sensor running empty while measurement is in progress.

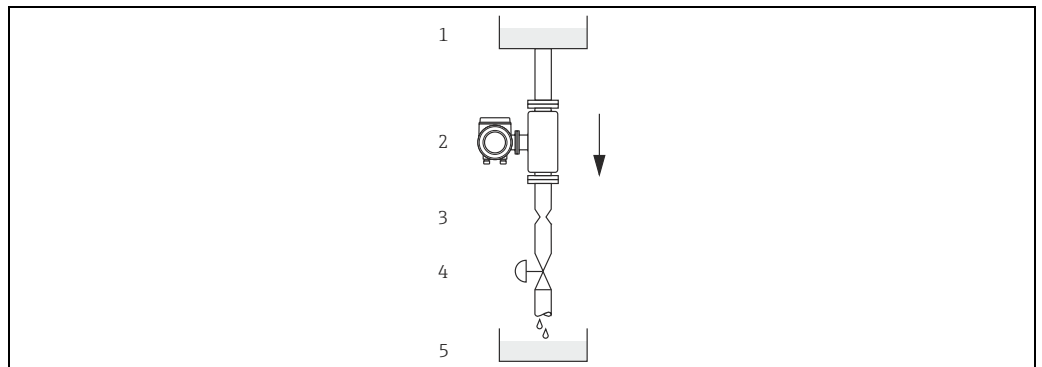

a0003597



Installation in a down pipe (e.g. for batching applications)

1 = Supply tank, 2 = Sensor, 3 = Orifice plate, pipe restriction (see table on following page), 4 = Valve, 5 = Batching tank

DN		Ø Orifice plate, pipe restriction	
[mm]	[in]	mm	in
80	3"	50	2.00
100	4"	65	2.60
150	6"	90	3.54

Orientation

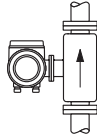
Make sure that the direction of the arrow on the nameplate of the sensor matches the direction of flow (direction in which the fluid flows through the pipe).

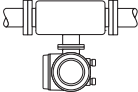
Orientation	Vertical	Horizontal, Transmitter head up	Horizontal, Transmitter head down
	 <small>a0004572</small> <i>Fig. V</i>	 <small>a0004576</small> <i>Fig. H1</i>	 <small>a0004580</small> <i>Fig. H2</i>
Standard, Compact version	✓✓	✓✓	✓✓
Standard, Remote version	✓✓	✓✓	✓✓

✓✓ = Recommended orientation; ✓ = Orientation recommended in certain situations; ✗ = Impermissible orientation

Vertical (Fig. V)

Recommended orientation with upward direction of flow (Fig. V). When fluid is not flowing, entrained solids will sink down and gases will rise away from the measuring tube. The measuring tubes can be completely drained and protected against solids build-up.

Horizontal (Fig. H1, H2)

The measuring tubes must be horizontal and beside each other. When installation is correct the transmitter housing is above or below the pipe (Fig. H1, H2). Always avoid having the transmitter housing in the same horizontal plane as the pipe.



Caution!

Both measuring tubes are slightly curved. The position of the sensor, therefore, has to be matched to the fluid properties when the sensor is installed horizontally.

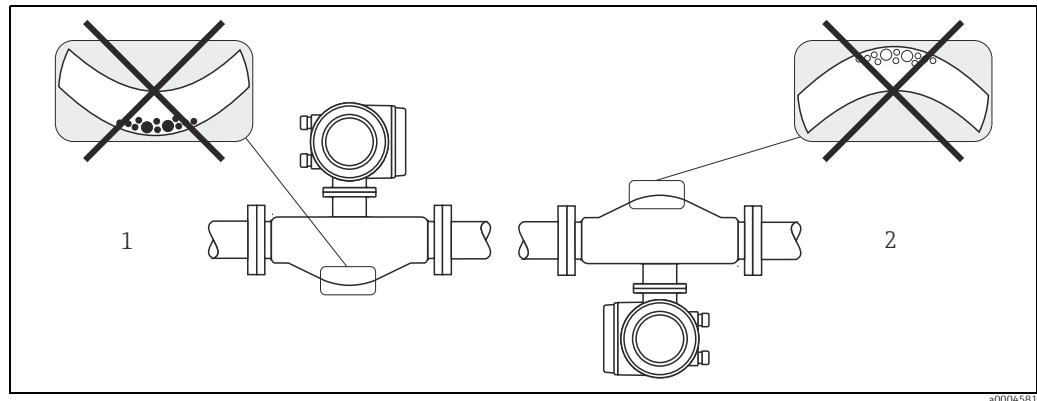

Horizontal installation

- 1 Not suitable for fluids with entrained solids. Risk of solids accumulating.
- 2 Not suitable for outgassing fluids. Risk of air accumulating.

Installation instructions

Note the following points:

- No special measures such as supports are necessary. External forces are absorbed by the construction of the instrument, for example the secondary containment.
- The high oscillation frequency of the measuring tubes ensures that the correct operation of the measuring system is not influenced by pipe vibrations.
- No special precautions need to be taken for fittings which create turbulence (valves, elbows, T-pieces, etc.), as long as no cavitation occurs.
- For mechanical reasons and to protect the pipe, support is recommended for heavy sensors.

Inlet and outlet runs

There are no installation requirements regarding inlet and outlet runs.

Length of connecting cable max. 20 m (65 ft), remote version

Special installation instructions

Rupture disk

Make sure that the function and operation of the rupture disk is not impeded through the installation of the device. The position of the rupture disk is indicated on a sticker beside it. For additional information that is relevant to the process (→ ☰ 30).

The existing connecting nozzles are not designed for a rinse or pressure monitoring function.

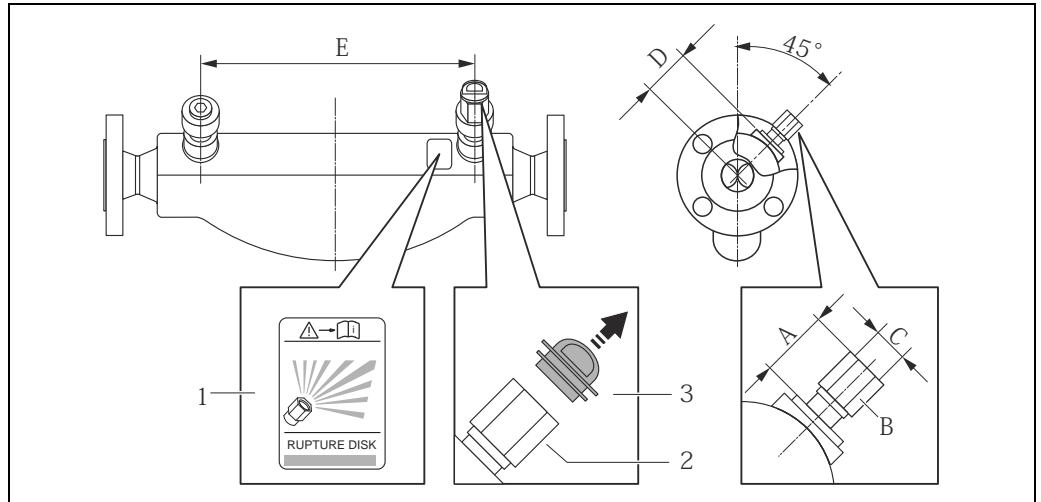

A0008361

- 1 Indication label for the rupture disk
- 2 ½" NPT internal screw thread with 1" width across flat
- 3 Transport protection

DN		E		F	G	H		L	
[mm]	[in]	[mm]	[in]			[mm]	[in]	[mm]	[in]
80	3"	approx. 42	approx. 1.65	SW 1"	½"-NPT	101	3.98	560	22.0
100	4"	approx. 42	approx. 1.65	SW 1"	½"-NPT	120	4.72	684	27.0
150	6"	approx. 42	approx. 1.65	SW 1"	½"-NPT	141	5.55	880	34.6

Zero point adjustment

All measuring devices are calibrated to state-of-the-art technology. Calibration takes place under reference operating conditions → ☰ 9. Consequently, the zero point adjustment is generally not necessary.

Experience shows that the zero point adjustment is advisable only in special cases:

- To achieve highest measuring accuracy also with small flow rates.
- Under extreme process or operating conditions (e.g. very high process temperatures or very high-viscosity fluids).

Environment

Ambient temperature range	Sensor and transmitter <ul style="list-style-type: none"> ■ Standard: -20 to +60 °C (-4 to +140 °F) ■ Optional: -40 to +60 °C (-40 to +140 °F)
	 Note! <ul style="list-style-type: none"> ■ Install the device at a shady location. Avoid direct sunlight, particularly in warm climatic regions. ■ At ambient temperatures below -20 °C (-4 °F) the readability of the display may be impaired.
Storage temperature	-40 to +80 °C (-40 to +176 °F), preferably +20 °C (+68 °F)
Degree of protection	Standard: IP 67 (NEMA 4X) for transmitter and sensor
Shock resistance	In accordance with IEC/EN 60068-2-31
Vibration resistance	Acceleration up to 1 g, 10 to 150 Hz, following IEC/EN 60068-2-6
Electromagnetic compatibility (EMC)	To IEC/EN 61326 and NAMUR Recommendation NE 21

Process

Medium temperature range	Sensor -40 to +200 °C (-40 to +392 °F)
Fluid density range	0 to 5000 kg/m ³ (0 to 312 lb/ft ³)
Medium pressure range (nominal pressure)	Flanges <ul style="list-style-type: none"> ■ According to DIN PN 160, PN 250 ■ According to ASME B16.5 Cl 900, Cl 1500

Secondary containment pressure rating

The sensor housing is filled with dry nitrogen and protects the electronics and mechanics inside.

The following secondary containment pressure rating is only valid for a fully welded sensor housing and/or a device equipped with closed purge connections (never opened, as delivered).

Nominal pressure according to ASME BPVC.

DN		Secondary containment rating (designed with a safety factor ≥ 4)		Burst pressure of secondary containment	
[mm]	[in]	[bar]	[psi]	[bar]	[psi]
80	3"	16	232	95	1440
100	4"	16	232	90	1360
150	6"	16	232	85	1270



Note!

In case a danger of measuring tube failure exists due to process characteristics, e.g. with corrosive process fluids, we recommend the use of sensors whose secondary containment is equipped with special pressure monitoring connections (ordering option). With the help of these connections, fluid collected in the secondary containment in the event of tube failure can be bled off.

This is especially important in high pressure gas applications. These connections can also be used for gas circulation and/or gas detection (dimensions → 21).

Do not open the purge connections unless the containment can be filled immediately with a dry inert gas. Use only low gauge pressure to purge. Maximum pressure: 5 bar (72.5 psi).

If a device equipped with purge connections is connected to the purge system, the maximum pressure rating is defined by the purge system itself or the device, whichever is lower. If the device is equipped with a rupture disk, the maximum pressure rating is defined by the rupture disk properties (→ 30).

Pressure-temperature ratings



Warning!

The following material load curves refer to the entire sensor and not just the process connection.

Flange connection according to EN 1092-1 (DIN 2501)

Flange material: 25Cr Duplex (Super Duplex), 1.4410 (UNS S32750)

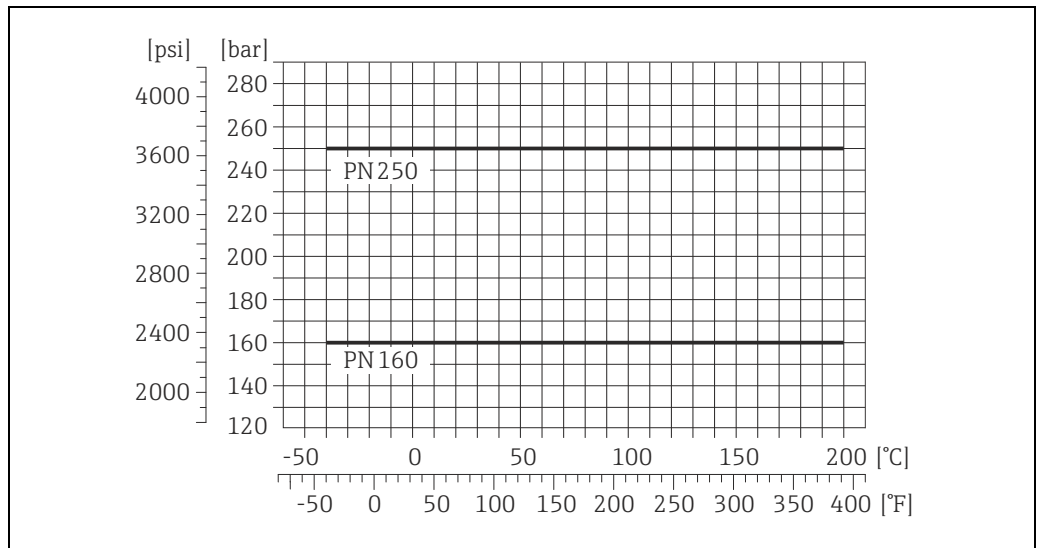







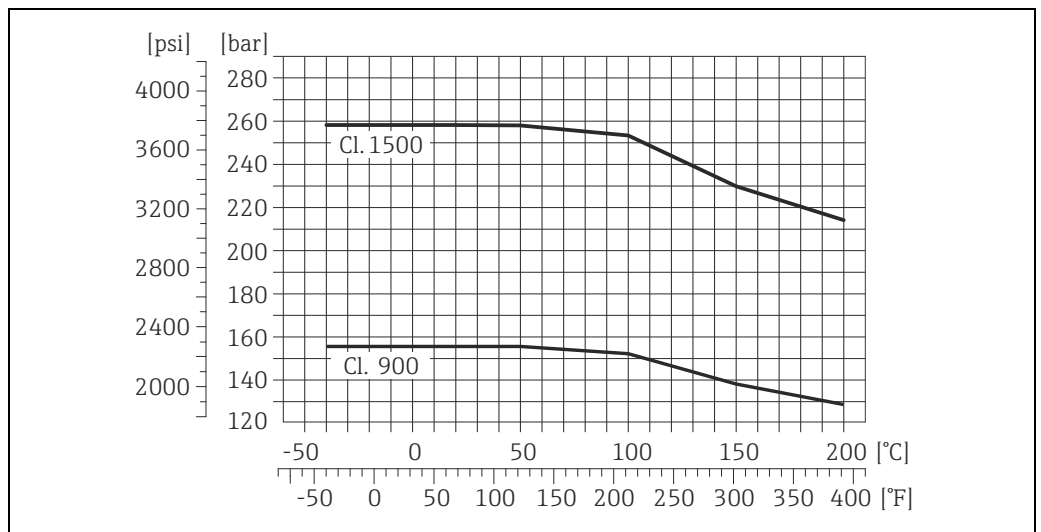

A0021180-EN

Flange connection according to ASME B16.5

Flange material: 25Cr Duplex (Super Duplex), 1.4410 (UNS S32750)



A0021181-EN

Rupture disk	To increase the level of safety, a device version with a rupture disk with a triggering pressure of 10 to 15 bar (145 to 217.5 psi) can be used. Special mounting instructions: (→  15). Rupture disks cannot be combined with the separately available heating jacket (→  34).
Limiting flow	See information in the "Measuring range" Section →  4 Select nominal diameter by optimizing between required flow range and permissible pressure loss. An overview of max. possible full scale values can be found in the "Measuring range" Section. <ul style="list-style-type: none"> ■ The minimum recommended full scale value is approx. 1/20 of the max. full scale value. ■ In most applications, 20 to 50% of the maximum full scale value can be considered ideal. ■ Select a lower full scale value for abrasive substances such as fluids with entrained solids (flow velocity <1 m/s (<3 ft/s)). ■ For gas measurement the following rules apply: <ul style="list-style-type: none"> - Flow velocity in the measuring tubes should not be more than half the sonic velocity (0.5 Mach). - The maximum mass flow depends on the density of the gas: formula →  4.
Pressure loss	To calculate the pressure loss, use the <i>Applicator</i> sizing tool (→  35).
System pressure	It is important to ensure that cavitation does not occur, because it would influence the oscillation of the measuring tube. No special measures need to be taken for fluids which have properties similar to water under normal conditions. In the case of liquids with a low boiling point (hydrocarbons, solvents, liquefied gases) or in suction lines, it is important to ensure that pressure does not drop below the vapor pressure and that the liquid does not start to boil. It is also important to ensure that the gases that occur naturally in many liquids do not outgas. Such effects can be prevented when system pressure is sufficiently high. For this reason, the following mounting locations are preferred: <ul style="list-style-type: none"> ■ Downstream from pumps (no risk of partial vacuum) ■ At the lowest point in a vertical pipe
Heating	<div style="display: flex; align-items: flex-start;"> <div style="margin-right: 10px;">  </div> <div> <p>Some fluids require suitable measures to avoid loss of heat at the sensor. Heating can be electric, e.g. with heated elements, or by means of hot water or steam pipes made of copper or heating jackets.</p> <p>Caution!</p> <ul style="list-style-type: none"> ■ Risk of electronics overheating! Make sure that the maximum permissible ambient temperature for the transmitter is not exceeded. Consequently, make sure that the adapter between sensor and transmitter and the connection housing of the remote version always remain free of insulating material. Note that a certain orientation might be required, depending on the fluid temperature →  16. <p>For fluid temperature of 150°C (302°F) or above the usage of the remote version with separate connection housing is recommended.</p> <ul style="list-style-type: none"> ■ When using electrical heat tracing whose heat is regulated using phase control or by pulse packs, it cannot be ruled out that the measured values are influenced by magnetic fields which may occur, (i.e. at values greater than those permitted by the EC standard (Sinus 30 A/m)). In such cases, the sensor must be magnetically shielded. <p>The secondary containment can be shielded with tin plates or electric sheets without privileged direction (e.g. V330-35A) with the following properties:</p> <ul style="list-style-type: none"> - Relative magnetic permeability $\mu_r \geq 300$ - Plate thickness $d \geq 0.35$ mm ($d \geq 0.01$") <ul style="list-style-type: none"> ■ Information on permissible temperature ranges →  16 <p>Special heating jackets which can be ordered as accessories from Endress+Hauser are available for the sensors.</p> </div> </div>

Custody transfer measurement

Promass 84 is a flowmeter suitable for custody transfer measurement for liquids (other than water) and gases.

Custody transfer variables

- Mass flow
- Volume flow
- Density

Suitability for custody transfer, metrological control, obligation to subsequent verification



Promass 84 flowmeters are usually verified on site using reference measurements. Only once it has been verified on site by the Verification Authority for legal metrology controls may the measuring device be regarded as verified and used for applications subject to legal metrology controls. The associated seal (stamp) on the measuring device ensures this status.

Caution!

Only flowmeters verified by the Verification Authorities may be used for invoicing in applications subject to legal metrology controls. For all verification processes, both the corresponding approvals and the country-specific requirements resp. regulations (e.g. such as the German Verification Act) must be observed. The owner / user of the instrument is obliged to subsequent verification.

Approval for custody transfer

The requirements of the following legal metrology authorities are taken into consideration:

- **PTB**, Germany; (www.eichamt.de)
- **METAS**, Switzerland; (www.metas.ch)
- **NMI**, The Netherlands; (www.nmi.nl)
- **BEV**, Austria; (www.bev.gv.at)
- **NTEP**, USA; (www.ncwm.net)
- **MC**, Canada; (www.ic.gc.ca)

Switching on the power supply in custody transfer mode

If the device is started in custody transfer mode, for example also after a power outage, system error No. 271 "POWER BRK. DOWN" flashes on the local display. The fault message can be acknowledged or reset using the "Enter" key or by means of the status input configured accordingly.



Note!

For correct measuring operation, it is not mandatory to reset the fault message.

Verification (Example)

Type-approved measuring systems for liquids other than water are always verified at their place of deployment. For this purpose, the facility's owner-operator must make everything available when the Verification Authorities come to inspect and verify the system. This includes:

- Scales or container with a reading unit with a load or volumetric capacity that corresponds to the operation of the system at Q_{max} for one minute. The resolution of the scales display or the reading unit must be at least 0.1 % of the minimum measured quantity.
- Unit for removing the medium being measured after the totalizer to fill the scales or the container.
- Making a sufficient quantity of the medium being measured available. The quantity is derived from the operation of the system. The following rule of thumb applies - quantity at:
 - 3×1 minute at Q_{min} ,
 - plus 3×1 minute at $\frac{1}{2} Q_{max}$,
 - plus 3×1 minute at Q_{max} ,
 - plus adequate quantity in reserve.
- Approval certificates



Note!

All issues should be clarified in advance with the authority responsible to ensure the successful verification of the measuring system.

Setting up custody transfer mode

A detailed description of the "setting up custody transfer mode" process is provided in the Operating Instructions supplied with the device.

Stamp points

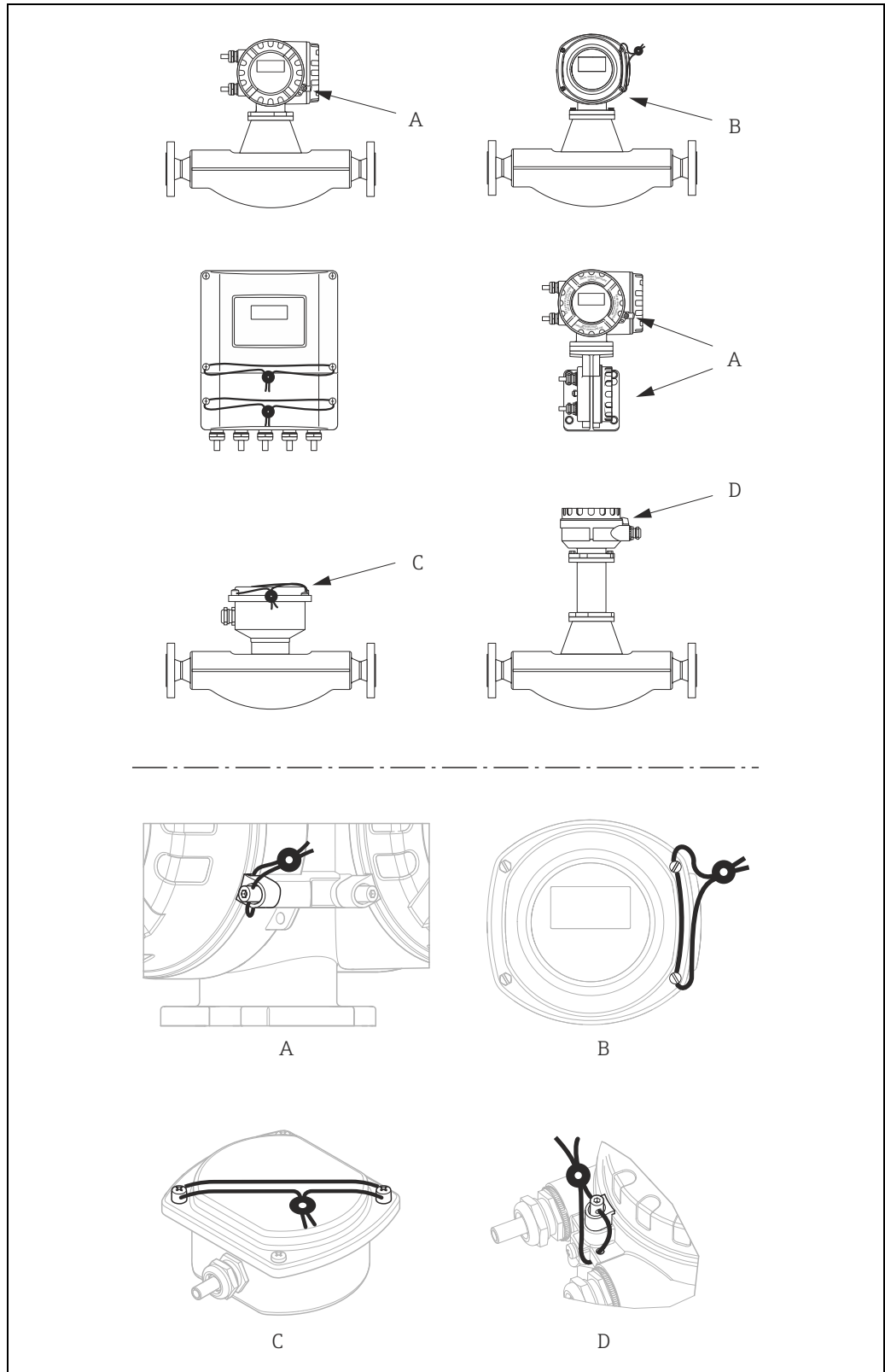

a0001778











Examples of how to seal the various device versions.

Disabling custody transfer mode

A detailed description of the "disabling custody transfer mode" process is provided in the Operating Instructions supplied with the device.

Mechanical construction

Design, dimensions

Dimensions:	
Field housing compact version, powder-coated die-cast aluminum	→  22
Field housing compact version, powder-coated die-cast aluminum (II2G/Zone1)	→  23
Transmitter compact version, stainless steel	→  24
Transmitter remote version, connection housing (II2G/Zone 1)	→  24
Transmitter remote version, wall-mount housing (non Ex-zone and II3G/Zone 2)	→  25
Sensor remote version, connection housing	→  26
Process connections in SI units	
Flange connections EN (DIN)	→  27
Flange connections ASME B16.5	→  28
Process connection in US units	
Process connections in US units	→  29
Purge connections / secondary containment monitoring	→  30

Field housing compact version, powder-coated die-cast aluminum

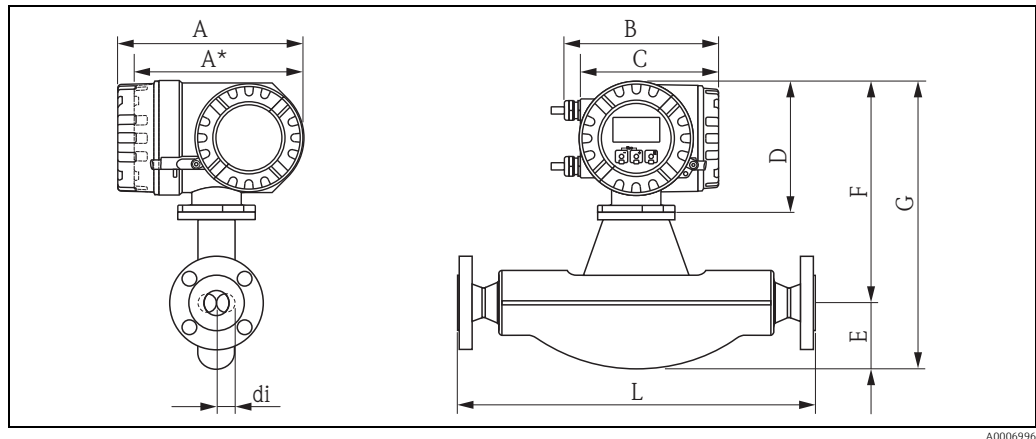

Dimensions in SI units

DN	A	A*	B	C	D	E	F	G	L	di
80	227	207	187	168	160	200	305	505	1)	1)
100	227	207	187	168	160	254	324	578	1)	1)
150	227	207	187	168	160	378	362	740	1)	1)

*Blind version (without display)

¹⁾ dependent on respective process connection

All dimensions in [mm];

Dimensions in US units

DN	A	A*	B	C	D	E	F	G	L	di
3"	8.94	8.15	7.68	6.61	6.30	7.87	12.0	19.9	1)	1)
4"	8.94	8.15	7.68	6.61	6.30	10.0	12.8	22.8	1)	1)
6"	8.94	8.15	7.68	6.61	6.30	14.9	14.3	29.1	1)	1)

*Blind version (without display)

¹⁾ dependent on respective process connection

All dimensions in [in];



Note!

Dimensions for transmitters II2G/Zone 1 → 23

Field housing compact version, powder-coated die-cast aluminum (II2G/Zone1)

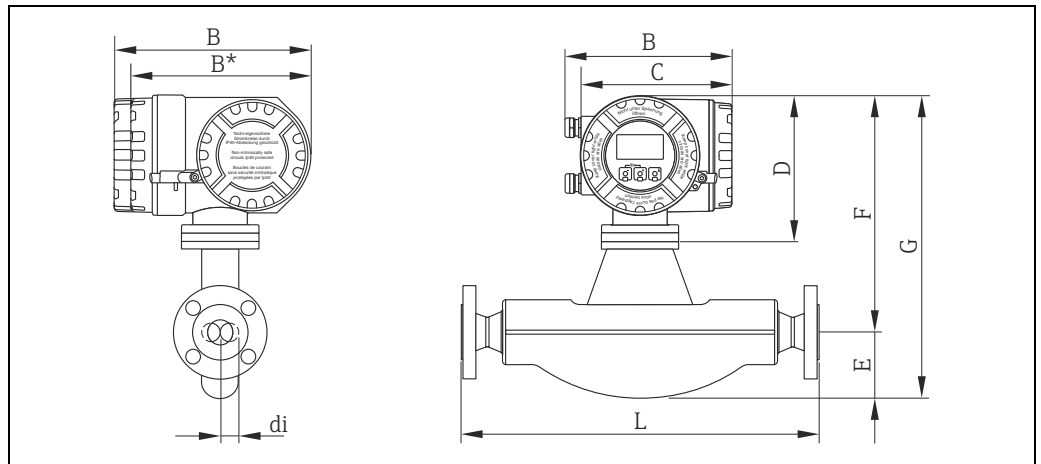

Dimensions in SI units

DN	A	A*	B	C	D	E	F	G	L	di
80	240	217	206	186	178	200	323	523	1) ¹⁾	1) ¹⁾
100	240	217	206	186	178	254	342	589	1) ¹⁾	1) ¹⁾
150	240	217	206	186	178	378	380	758	1) ¹⁾	1) ¹⁾

*Blind version (without display)

¹⁾ dependent on respective process connection

All dimensions in [mm];

Dimensions in US units

DN	A	A*	B	C	D	E	F	G	L	di
3"	9.45	8.54	8.11	7.32	7.01	7.87	12.72	20.59	1) ¹⁾	1) ¹⁾
4"	9.45	8.54	8.11	7.32	7.01	10.00	13.46	23.19	1) ¹⁾	1) ¹⁾
6"	9.45	8.54	8.11	7.32	7.01	14.88	14.96	29.84	1) ¹⁾	1) ¹⁾

*Blind version (without display)

¹⁾ dependent on respective process connection

All dimensions in [in];



Note!

Dimensions for remote version II2G/Zone 1 → 24

Transmitter compact version, stainless steel

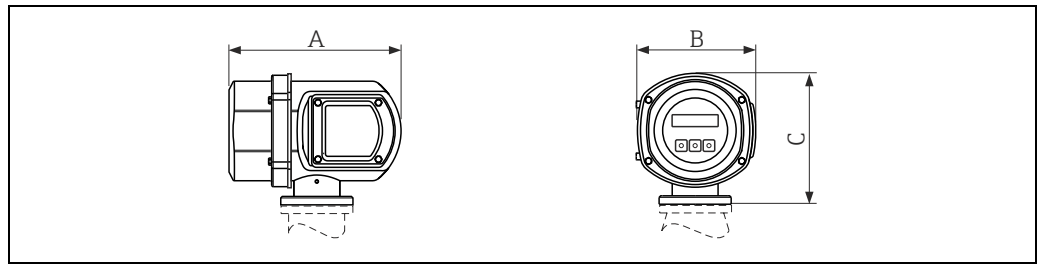

a0002245

Dimensions in SI and US units

A		B		C	
[mm]	[in]	[mm]	[in]	[mm]	[in]
225	8.86	153	6.02	168	6.61

Transmitter remote version, connection housing (II2G/Zone 1)

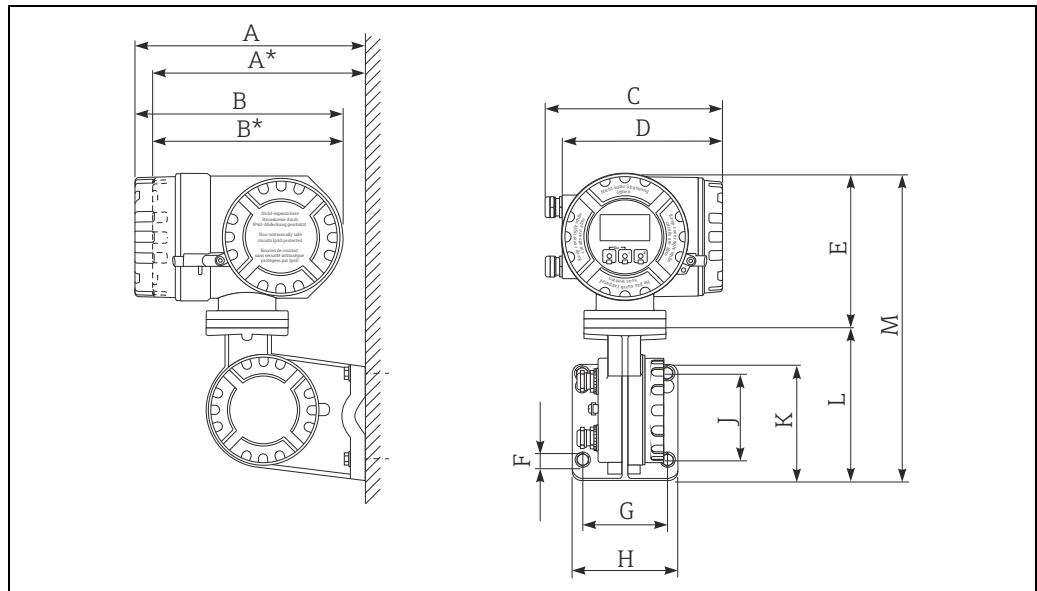

a0002128

Dimensions in SI units

A	A*	B	B*	C	D	E	F Ø	G	H	J	K	L	M
265	242	240	217	206	186	178	8.6 (M8)	100	130	100	144	170	348

* Blind version (without display)
All dimensions in [mm]

Dimensions in US units

A	A*	B	B*	C	D	E	F Ø	G	H	J	K	L	M
10.4	9.53	9.45	8.54	8.11	7.32	7.01	0.34 (M8)	3.94	5.12	3.94	5.67	6.69	13.7

* Blind version (without display)
All dimensions in [in]

Transmitter remote version, wall-mount housing (non Ex-zone and II3G/Zone 2)

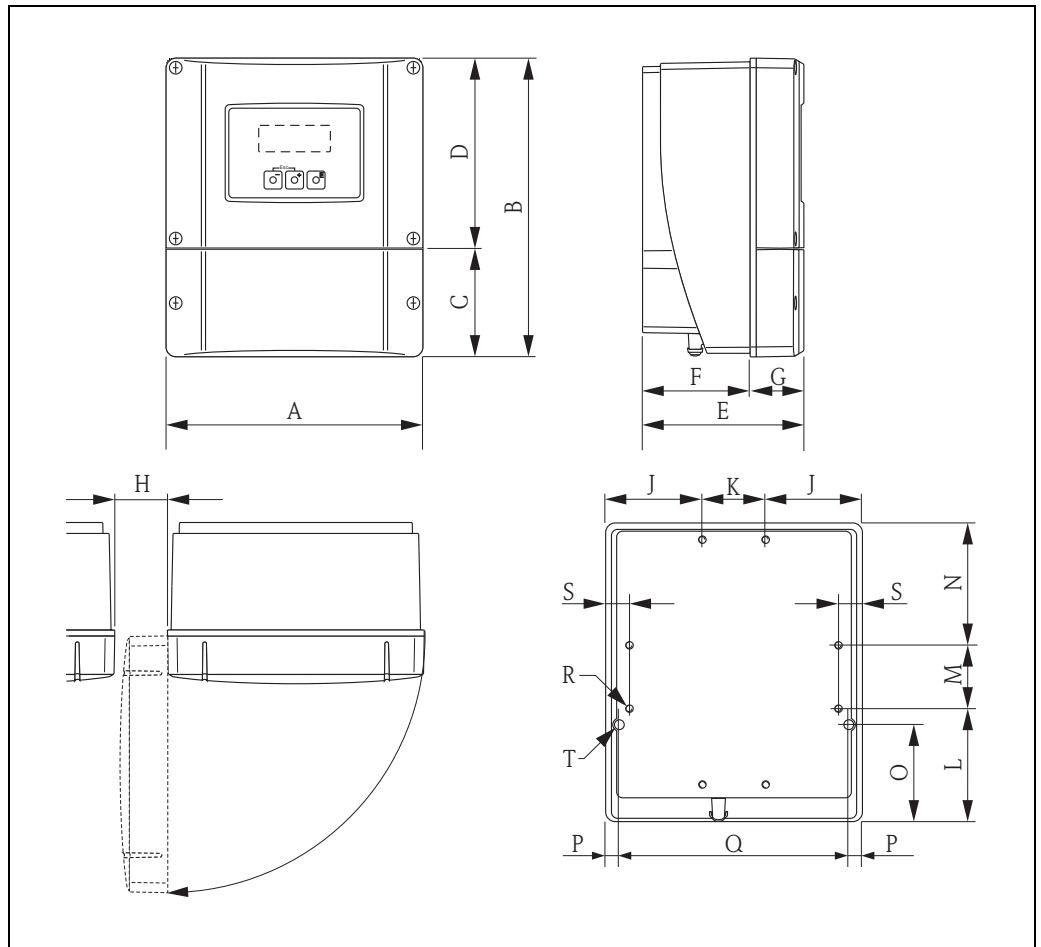

a0001150

Dimensions in SI units

A	B	C	D	E	F	G	H	J	K
215	250	90.5	159.5	135	90	45	>50	81	53
L	M	N	O	P	Q	R	S	T ¹⁾	
95	53	102	81.5	11.5	192	8 × M5	20	2 × Ø 6.5	

¹⁾ Fixing bolt for wall assembly: M6 (screw head max. 10.5 mm)
All dimensions in [mm]

Dimensions in US units

A	B	C	D	E	F	G	H	J	K
8.46	9.84	3.56	6.27	5.31	3.54	1.77	>1.97	3.18	2.08
L	M	N	O	P	Q	R	S	T ¹⁾	
3.74	2.08	4.01	3.20	0.45	7.55	8 × M5	0.79	2 × Ø 0.26	

¹⁾ Fixing bolt for wall assembly: M6 (screw head max. 0.41 in)
All dimensions in [in]

Sensor remote version, connection housing

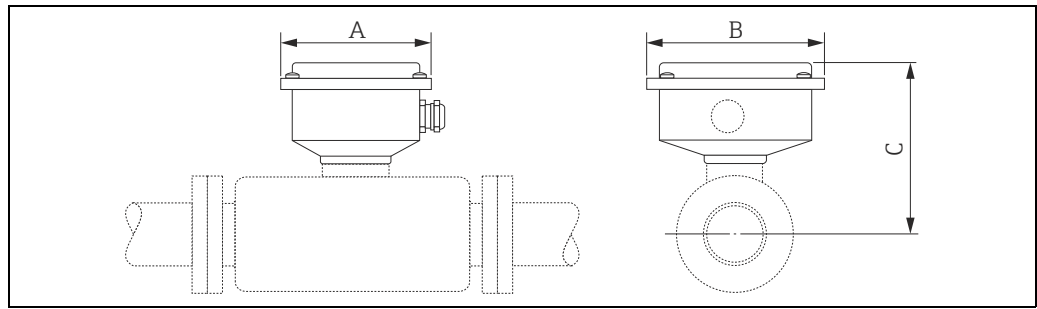

a0002516

Dimensions in SI units

DN	A	B	C
80	118.5	137.5	152
100	118.5	137.5	171
150	118.5	137.5	209

All dimensions in [mm]

Dimensions in US units

DN	A	B	C
3"	4.67	5.41	6.08
4"	4.67	5.41	6.84
6"	4.67	5.41	8.36

All dimensions in [in]

Process connections in SI units

Flange connections EN (DIN), ASME B16.5

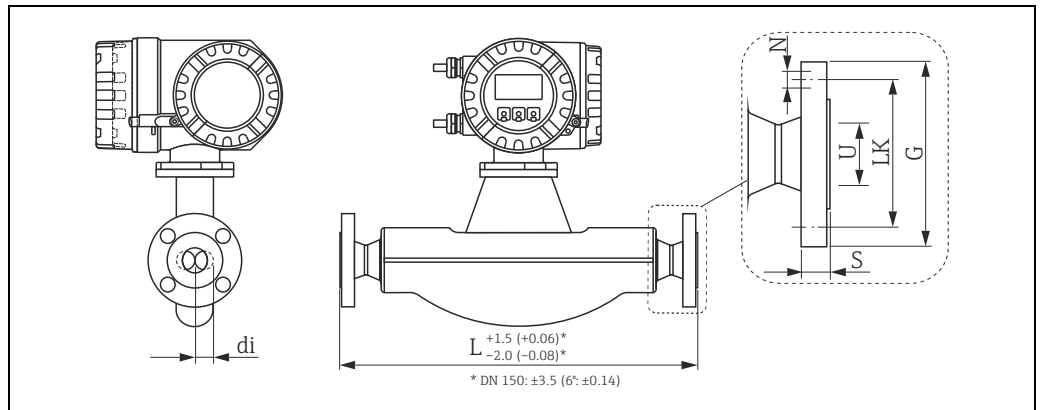

Dimension unit in mm (in)

Flange connections EN (DIN)

**Flange according to EN 1092-1 (DIN 2501) / PN 160: 25Cr Duplex (Super Duplex), 1.4410 (UNS S32750)
Optionally supplied with or without notch (Form D).**

Surface roughness (flange): EN 1092-1 Form B2 or Form D (DIN 2526 Form E), Ra 0.8 to 3.2 µm

DN	G	L	N	S	LK	U	di
80	230	916	8 × Ø 26	36	180	80.9	38.5
100	265	1208	8 × Ø 30	40	210	104.3	49.0
150	355	1476	12 × Ø 33	50	290	155.7	66.1

All dimensions in [mm]

**Flange according to EN 1092-1 (DIN 2501) / PN 250: 25Cr Duplex (Super Duplex), 1.4410 (UNS S32750)
Optionally supplied with or without notch (Form D).**

Surface roughness (flange): EN 1092-1 Form B2 or Form D (DIN 2526 Form E), Ra 0.8 to 3.2 µm

DN	G	L	N	S	LK	U	di
80	255	948	8 × Ø 30	46	200	77.7	38.5
100	300	1248	8 × Ø 33	54	235	100.3	49.0
150	390	1540	12 × Ø 36	68	320	148.3	66.1

All dimensions in [mm]

Flange connections ASME B16.5

Flange according to ASME B16.5 / Cl 900 Sched 40/Sched 80: 25Cr Duplex (Super Duplex), 1.4410 (UNS S32750)								
Surface roughness (flange): Ra 3.2 to 6.3 µm								
DN	G	L	N	S	LK	U		di
						Sched 40	Sched 80	
80	241.3	962	8 × Ø 25.4	45.1	190.5	78.0	73.7	38.5
100	292.1	1251	8 × Ø 31.8	51.4	234.9	102.4	97.3	49.0
150	381.0	1513	12 × Ø 31.8	62.6	317.5	154.1	146.3	66.1

All dimensions in [mm]

Flange according to ASME B16.5 / Cl 1500 Sched 80: 25Cr Duplex (Super Duplex), 1.4410 (UNS S32750)								
Surface roughness (flange): Ra 3.2 to 6.3 µm								
DN	G	L	N	S	LK	U	di	
80	266.7	993	8 × Ø 31.8	54.8	203.2	73.7	38.5	
100	311.2	1270	8 × Ø 35.1	60.8	241.3	97.3	49.0	
150	393.7	1577	12 × Ø 38.1	89.6	317.5	146.3	66.1	

All dimensions in [mm]

RTJ-Flange according to ASME B16.5 / Cl 900 Sched 40/Sched 80: 25Cr Duplex (Super Duplex), 1.4410 (UNS S32750)								
Surface roughness (flange): Ra 3.2 to 6.3 µm								
DN	G	L	N	S	LK	U		di
						Sched 40	Sched 80	
80	241.3	963	8 × Ø 25.4	46.0	190.5	78.0	73.7	38.5
100	292.1	1252	8 × Ø 31.8	52.3	234.9	102.4	97.3	49.0
150	381.0	1515	12 × Ø 31.8	63.5	317.5	154.1	146.3	66.1

All dimensions in [mm]

RTJ-Flange according to ASME B16.5 / Cl 1500 Sched 80: 25Cr Duplex (Super Duplex), 1.4410 (UNS S32750)								
Surface roughness (flange): Ra 3.2 to 6.3 µm								
DN	G	L	N	S	LK	U	di	
80	266.7	995	8 × Ø 31.8	55.7	203.2	73.7	38.5	
100	311.2	1272	8 × Ø 35.1	61.7	241.3	97.3	49.0	
150	393.7	1582	12 × Ø 38.1	92.1	317.5	146.3	66.1	

All dimensions in [mm]

Process connections in US units

Flange connections ASME B16.5

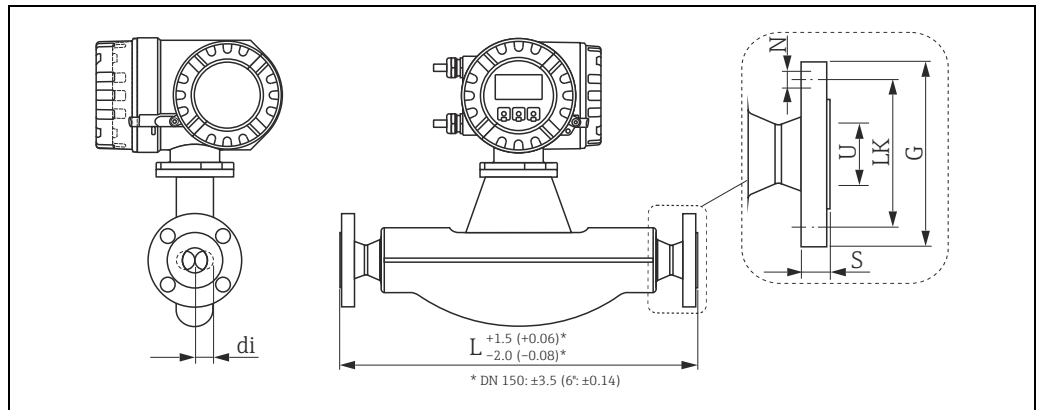

Dimension unit in mm (in)

A0002501

Flange according to ASME B16.5 / CI 900 Sched 40/Sched 80: 25Cr Duplex (Super Duplex), 1.4410 (UNS S32750)

Surface roughness (flange): Ra 3.2 to 6.3 µm

DN	G	L	N	S	LK	U		di
						Sched 40	Sched 80	
3"	9.50	37.87	8 × Ø 1.00	1.78	7.50	3.07	2.90	1.52
4"	11.50	49.25	8 × Ø 1.25	2.02	9.25	4.03	3.83	1.93
6"	15.00	59.57	12 × Ø 1.25	2.46	12.50	6.07	5.76	2.60

All dimensions in [in]

Flange according to ASME B16.5 / CI 1500 Sched 80: 25Cr Duplex (Super Duplex), 1.4410 (UNS S32750)

Surface roughness (flange): Ra 3.2 to 6.3 µm

DN	G	L	N	S	LK	U	di
3"	10.50	39.09	8 × Ø 1.00	2.16	8.00	2.90	1.52
4"	12.25	50.00	8 × Ø 1.38	2.39	9.50	3.83	1.93
6"	15.50	62.09	12 × Ø 1.50	3.53	12.50	5.76	2.60

All dimensions in [in]

RTJ-Flange according to ASME B16.5 / CI 900 Sched 40/Sched 80: 25Cr Duplex (Super Duplex), 1.4410 (UNS S32750)

Surface roughness (flange): Ra 3.2 to 6.3 µm

DN	G	L	N	S	LK	U		di
						Sched 40	Sched 80	
3"	9.50	37.91	8 × Ø 1.00	1.81	7.50	3.07	2.90	1.52
4"	11.50	49.29	8 × Ø 1.25	2.06	9.25	4.03	3.83	1.93
6"	15.00	59.65	12 × Ø 1.25	2.50	12.50	6.07	5.76	2.60

All dimensions in [in]

RTJ-Flange according to ASME B16.5 / Cl 1500 Sched 80: 25Cr Duplex (Super Duplex), 1.4410 (UNS S32750)
Surface roughness (flange): Ra 3.2 to 6.3 µm

DN	G	L	N	S	LK	U	di
80	10.50	39.17	8 × Ø 1.00	2.19	8.00	2.90	1.52
100	12.25	50.08	8 × Ø 1.38	2.43	9.50	3.83	1.93
150	15.50	62.28	12 × Ø 1.50	3.63	12.50	5.76	2.60

All dimensions in [in]

Purge connections / secondary containment monitoring

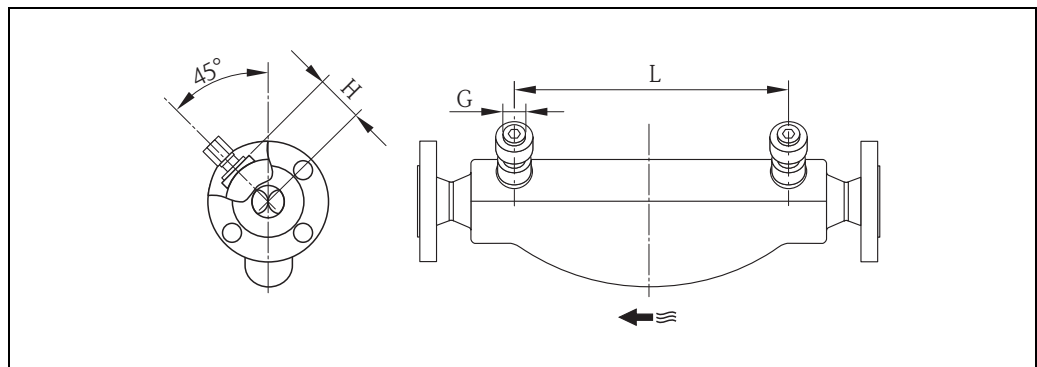

a0002537

DN		G	H		L	
[mm]	[in]		[mm]	[in]	[mm]	[in]
80	3"	½"-NPT	101	3.98	560	22.0
100	4"	½"-NPT	120	4.72	684	27.0
150	6"	½"-NPT	141	5.55	880	34.6

Weight

- Compact version: see tables below
- Remote version
 - Transmitter: see the tables below
 - Wall-mount housing: 5 kg (11 lbs)
 - Compact version Ex d (stainless steel): + 9kg (+ 20 lb)

Weight information in SI units

DN [mm]	80	100	150
Compact version	75	141	246
Remote version	73	139	244

All values (weight) refer to devices with Cl 900 flanges according to ASME
 Weight information in [kg].

Weight information in US

DN [in]	3"	4"	6"
Compact version	165	311	542
Remote version	161	306	538

All values (weight) refer to devices with CI 900 flanges according to ASME
Weight information in [lbs].

Material**Transmitter housing**

Compact version

- Stainless steel housing: stainless steel, 1.4301 (304)
- Stainless steel housing (II2G/Zone 1): stainless steel, 1.4404 (316/316L)
- Powder coated die-cast aluminum
- Window material: Glass or polycarbonate

Remote version

- Remote field housing: powder coated die-cast aluminum
- Wall-mount housing: powder coated die-cast aluminum
- Window material: Glass

Sensor housing / containment

- Acid and alkali-resistant outer surface
- Stainless steel, 1.4404 (316L)

Connection housing, sensor (remote version)

- Stainless steel, 1.4301 (304) (standard)
- Powder coated die-cast aluminum

Process connections

Flanges according to EN 1092-1 (DIN 2501) / according to ASME B16.5:

- Stainless steel, 25Cr Duplex (Super Duplex), 1.4410 (UNS S32750)

Measuring tubes

- Stainless steel, 25Cr Duplex (Super Duplex), 1.4410 (UNS S32750)

Process connections**Welded process connections**

Flanges according to EN 1092-1 (DIN 2501) and according to ASME B16.5

Operability**Local operation****Display elements**

- Liquid-crystal display: backlit and four lines with 16 characters per line
- Selectable display of different measured values and status variables
- At ambient temperatures below -20 °C (-4 °F) the readability of the display may be impaired.

Operating elements

- Local operation with three optical keys (☐ ⊕ ⊞)
- Application-specific Quick Setup menus for straightforward commissioning

Language group	<p>Language groups available for operation in different countries:</p> <ul style="list-style-type: none"> ▪ Western Europe and America (WEA): English, German, Spanish, Italian, French, Dutch and Portuguese ▪ Eastern Europe/Scandinavia (EES): English, Russian, Polish, Norwegian, Finnish, Swedish and Czech ▪ South and Eastern Asia (SEA): English, Japanese, Indonesian ▪ China (CN): English, Chinese <p>The language group is changed using the "FieldCare" operating program.</p>
-----------------------	--

Remote operation	Remote operation via HART, Modbus RS485
-------------------------	---

Certificates and approvals

CE mark	The measuring system is in conformity with the statutory requirements of the EC Directives. Endress+Hauser confirms successful testing of the device by affixing to it the CE mark.
C-Tick symbol	The measuring system complies with the EMC requirements of the "Australian Communications and Media Authority (ACMA)"
Ex approval	Information about currently available Ex versions (ATEX, FM, CSA, IECEx, NEPSI) can be supplied by your Endress+Hauser Sales Center on request. All explosion protection data are contained in separate explosion protection documentation which you can order if required.
Modbus certification	The measuring device meets all the requirements of the Modbus/TCP conformity and integration test and has the "Modbus/TCP Conformance Test Policy, Version 2.0". The measuring device has successfully passed all the test procedures carried out and is certified by the "Modbus/TCP Conformance Test Laboratory" of the University of Michigan.
Pressure equipment directive	<p>The measuring devices can be ordered with or without PED (Pressure Equipment Directive). If a device with PED is required, this must be ordered explicitly.</p> <ul style="list-style-type: none"> ▪ With the identification PED/G1/III on the sensor nameplate, Endress+Hauser confirms conformity with the "Basic safety requirements" of Appendix I of the Pressure Equipment Directive 97/23/EC. ▪ Devices with this identification (with PED) are suitable for the following types of fluid: <ul style="list-style-type: none"> - Fluids of Group 1 and 2 with a steam pressure of greater, or less than and equal to 0.5 bar (7.3 psi) - Unstable gases ▪ Devices without this identification (without PED) are designed and manufactured according to good engineering practice. They correspond to the requirements of Art. 3, Section 3 of the Pressure Equipment Directive 97/23/EC. Their application is illustrated in Diagrams 6 to 9 in Appendix II of the Pressure Equipment Directive 97/23/EC. <p>Optionally flowmeters in accordance to the guidelines AD 2000 are available on request.</p>

Measuring Instruments Directive

Measuring Instruments Directive 2004/22/EG (MID)

Annex MI-002 (gas meter)

The measuring device is approved as gas meter for use under legal control (in commercial transactions) acc. the European Measuring Instruments Directive, Annex MI-002 (DE-08-MI002-PTB014).

Annex MI-005 (liquids other than water)

- This flowmeter which is a suitable component in measuring systems subject to legal metrology controls in accordance with Annex MI-005 of the European Measuring Instruments Directive 2004/22/EC (MID)

Note: According to the Measuring Instruments Directive, however, only the complete measuring system is licensable, covered by an EC type-examination certificate and bears conformity marking.

- This flowmeter is qualified to OIML R117-1 and has an MID Evaluation Certificate (1) which confirms compliance with the essential requirements of the Measuring Instruments Directive. The Evaluation Certificate results from the WELMEC (cooperation between the legal metrology services of the member states of the European Union and EFTA) towards voluntary modular approval for measuring systems in accordance with Annex MI-005 (measuring systems for the continuous and dynamic measurement of quantities of liquids other than water) of the Measuring Instruments Directive 2004/22/EC.

Suitability for custody transfer measurement

MID approval, Annex MI-002 (gas meter)

The device is qualified to OIML R137/D11.

DN		MID Type Examination Certificate MI-002 (Europe)		
[mm]	[in]	Mass	Gases Volume	Density
80 to 150	3 to 6	YES	YES *	NO

* at pure gases only (invariable gas density)

MID approval, Annex MI-005 (liquids other than water)

The device is qualified to OIML R117-1.

DN		OIML R117-1/MID Evaluation Certificate (Europe)		
[mm]	[in]	Mass	Liquids other than water Volume	Density
80 to 150	3 to 6	YES	YES	YES

Approval for custody transfer

Promass 84 is a flowmeter suitable for custody transfer measurement for liquids (other than water) and for fuel gases. The requirements of the following test centres are taken into consideration:

- PTB, Germany
- NMi, The Netherlands
- METAS, Switzerland
- BEV, Austria
- NTEP, USA
- MC, Canada

Information on custody transfer measurement →  19

Other standards and guidelines

- EN 60529
Degrees of protection by housing (IP code)
- EN 61010-1
Protection Measures for Electrical Equipment for Measurement, Control, Regulation and Laboratory Procedures
- IEC/EN 61326
"Emission in accordance with Class A requirements". Electromagnetic compatibility (EMC requirements).
- NAMUR NE 21
Electromagnetic compatibility (EMC) of industrial process and laboratory control equipment
- NAMUR NE 43
Standardization of the signal level for the breakdown information of digital transmitters with analog output signal
- NAMUR NE 53
Software of field devices and signal-processing devices with digital electronics

Ordering Information

Detailed ordering information is available from the following sources:

- In the Product Configurator on the Endress+Hauser website: www.endress.com → Select country → Instruments → Select device → Product page function: Configure this product
- From your Endress+Hauser Sales Center: www.endress.com/worldwide



Note!

Product Configurator - the tool for individual product configuration

- Up-to-the-minute configuration data
- Depending on the device: Direct input of measuring point-specific information such as measuring range or operating language
- Automatic verification of exclusion criteria
- Automatic creation of the order code and its breakdown in PDF or Excel output format
- Ability to order directly in the Endress+Hauser Online Shop

Accessories

Various accessories, which can be ordered with the device or subsequently from Endress+Hauser, are available for the device. Detailed information on the order code in question is available from your local Endress+Hauser sales center or on the product page of the Endress+Hauser website: www.endress.com.

Device-specific accessories

For the Transmitter

Accessories	Description
Mounting set for transmitter	Mounting set for wall-mount housing (remote version). Suitable for: <ul style="list-style-type: none"> ▪ Wall mounting ▪ Pipe mounting ▪ Installation in control panel Mounting set for aluminum field housing: Suitable for pipe mounting (3/4" to 3")

For the Sensor

Accessories	Description
Heating jacket	Is used to stabilize the temperature of the fluids in the sensor. Water, water vapor and other non-corrosive liquids are permitted for use as fluids. If using oil as a heating medium, please consult with Endress+Hauser. Heating jackets cannot be used with sensors fitted with a rupture disk. For details, see Operating Instructions BA00099D

Communication-specific accessories

Accessories	Description
HART Communicator Field Xpert handheld terminal	Handheld terminal for remote parameterization and for obtaining measured values via the current output HART (4 to 20 mA). Contact your Endress +Hauser representative for more information.
Commubox FXA195 HART	The Commubox FXA195 connects intrinsically safe smart transmitters with the HART protocol with the USB port of a personal computer. This enables remote operation of the transmitter with operating software (e.g. FieldCare). Power is supplied to the Commubox via the USB port.

Service-specific accessories

Accessories	Description
Applicator	Software for selecting and sizing Endress+Hauser measuring devices: <ul style="list-style-type: none"> ▪ Calculation of all the necessary data for identifying the optimum flowmeter: e.g. nominal diameter, pressure loss, accuracy or process connections ▪ Graphic illustration of the calculation results Administration, documentation and access to all project-related data and parameters over the entire life cycle of a project. Applicator is available: <ul style="list-style-type: none"> ▪ Via the Internet: https://wapps.endress.com/applicator ▪ On CD-ROM for local PC installation
W@M	Life cycle management for your plant. W@M supports you with a wide range of software applications over the entire process: from planning and procurement, to the installation, commissioning and operation of the measuring devices. All the relevant device information, such as the device status, spare parts and device-specific documentation, is available for every device over the entire life cycle. The application already contains the data of your Endress+Hauser device. Endress+Hauser also takes care of maintaining and updating the data records. W@M is available: <ul style="list-style-type: none"> ▪ Via the Internet: www.endress.com/lifecyclemanagement ▪ On CD-ROM for local PC installation
Fieldcheck	Tester/simulator for testing flowmeters in the field. When used in conjunction with the "FieldCare" software package, test results can be imported into a database, printed and used for official certification. Contact your Endress+Hauser representative for more information.
FieldCare	FieldCare is Endress+Hauser's FDT-based plant asset management tool and allows the configuration and diagnosis of intelligent field devices. By using status information, you also have a simple but effective tool for monitoring devices. The Proline flowmeters are accessed via a service interface or via the service interface FXA193.
FXA193	Service interface from the measuring device to the PC for operation via FieldCare.

System components

Accessories	Description
Memograph M graphic display recorder	The Memograph M graphic display recorder provides information on all the relevant process variables. Measured values are recorded correctly, limit values are monitored and measuring points analyzed. The data are stored in the 256 MB internal memory and also on a DSD card or USB stick. Memograph M boasts a modular design, intuitive operation and a comprehensive security concept. The ReadWin® 2000 PC software is part of the standard package and is used for configuring, visualizing and archiving the data captured. The mathematics channels which are optionally available enable continuous monitoring of specific power consumption, boiler efficiency and other parameters which are important for efficient energy management.

Documentation

- Flow measuring technology (FA00005D)
- Operating Instructions/Description of Device Functions
 - Promass 84 HART (BA00109D/BA00110D)
 - Promass 84 Modbus RS485 (BA00129D/BA00130D)
- Supplementary documentation on Ex-ratings: ATEX, FM, CSA, IECEx NEPSI

Registered trademarks

HART®

Registered trademark of HART Communication Foundation, Austin, USA

Modbus®

Registered trademark of SCHNEIDER AUTOMATION, INC.

Applicator®, FieldCare®, Fieldcheck®, HistoROM™, F-CHIP®, S-DAT®, T-DAT™

Registered or registration-pending trademarks of the Endress+Hauser Group

www.addresses.endress.com
