

Technical Information

Teqwave T

Measuring device with surface acoustic wave technology



Smart, highly flexible solution for mobile concentration measurement – individually for your process

Application

- The acoustic waveguide measures precisely and reliably, even the smallest changes are detected
- Temporary concentration measurement of liquids at various measuring points in plant and laboratory

Device properties

- Accurate and independent of flow profile
- Insertion length: 180 mm (7")
- Robust, portable transmitter with Li-ion battery 2300 mAh
- Large color display with 4 operating keys
- Integrated data storage for max. 3000 measured values

Your benefits

- Easy, fast and efficient – real-time in situ liquid analysis
- Versatile applications – one device for changing tasks
- Highest process safety – reliable metering due to robust, maintenance-free sensor
- Cost-saving – mobile quality control
- Customized usage – innovative app concept, easily expandable for changing measuring tasks
- Fast, straightforward operation without metrology knowledge – pre-configured measuring points
- Efficient plant monitoring – up to 8 hours of mobile operation without external power supply





Table of contents

About this document	3	Ordering information	11
Symbols and abbreviations used	3	Accessories	11
Function and system design	4	Device-specific accessories	11
Measuring principle	4	Service-specific accessories	11
Measuring system	4	Documentation	12
Security	5	Standard documentation	12
Input	6	Registered trademarks	12
Measured variables	6		
Measuring ranges	6		
Power supply	6		
Supply voltage	6		
Power consumption	7		
Power supply failure	7		
Electrical connection	7		
Cable specification	7		
Performance characteristics	7		
Max. measured error	7		
Accuracy	7		
Measuring frequencies	7		
Influence of variations in the fluid temperature	8		
Influence of vibrations	8		
Influence of air bubbles	8		
Environment	8		
Ambient temperature range	8		
Storage temperature	8		
Degree of protection	8		
Electromagnetic compatibility (EMC)	8		
Process	8		
Medium temperature range	8		
Flow velocity	8		
Mechanical construction	9		
Dimensions	9		
Weight	9		
Materials	9		
Operability	10		
Local operation	10		
Operating tool	10		
Reliable operation	10		
Languages	10		
Certificates and approvals	10		
CE mark	10		
C-tick symbol	10		
Other standards and guidelines	10		







About this document

Symbols and abbreviations used

Electrical symbols

Symbol	Meaning
 A0011197	Direct current A terminal to which DC voltage is applied or through which direct current flows.
 A0011198	Alternating current A terminal to which alternating voltage is applied or through which alternating current flows.
 A0017381	Direct and alternating current <ul style="list-style-type: none"> ▪ A terminal to which alternating voltage or DC voltage is applied. ▪ A terminal through which alternating current or direct current flows.
 A0011200	Ground connection A grounded terminal which, as far as the operator is concerned, is grounded via a grounding system.

Symbols for certain types of information

Symbol	Meaning
 A0011182	Permitted Indicates procedures, processes or actions that are permitted.
 A0011183	Preferred Indicates procedures, processes or actions that are preferred.
 A0011184	Forbidden Indicates procedures, processes or actions that are forbidden.
 A0011193	Tip Indicates additional information.
 A0011194	Reference to documentation Refers to the corresponding device documentation.
 A0011195	Reference to page Refers to the corresponding page number.

Symbols in graphics

Symbol	Meaning
1, 2, 3, ...	Item numbers
A, B, C, ...	Views
A-A, B-B, C-C,..	Sections
 A0013441	Flow direction

Function and system design

Measuring principle

The core component of the measuring device is an acoustic wave guide for the precise and rapid measurement of liquid concentrations with acoustic surface waves.

A piezoelectric interdigital transducer (1) stimulates these high-frequency sound waves, which then propagate in the wall of the measuring device (A and B). A second piezoelectric interdigital transducer (2) acts as the receiver.

If the sound waves come into contact with liquid, the waves disperse into the liquid. This involves mode conversion at a Rayleigh angle (θ_R). This angle depends on the ratio of the speed of sound of the surface waves to the speed of sound of the liquid.

The double transducer arrangement with one transducer acting as a transmitter and another as a receiver enables extremely accurate analysis of the transmission times and amplitudes of the sound waves.

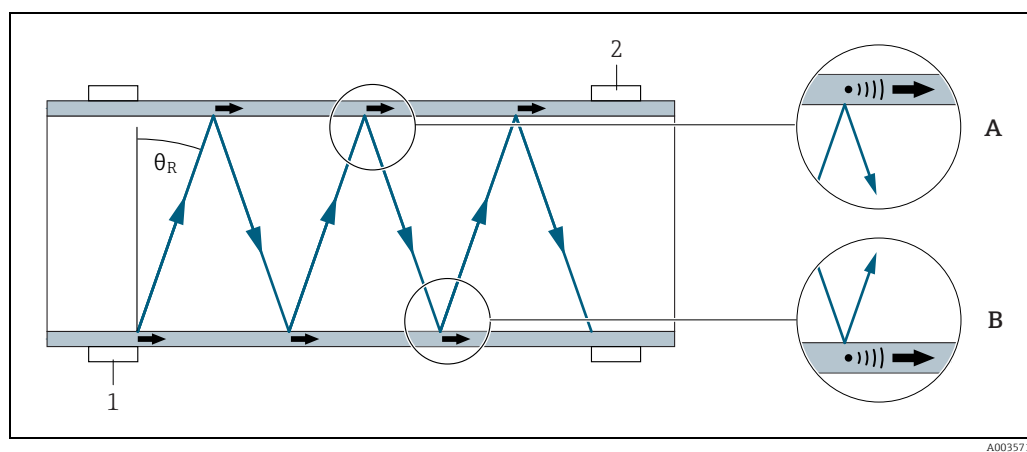

A0035710

During this process, the measuring device also determines the acoustic impedance and the acoustic density of the liquid, in addition to the speed of sound. Another sensor also measures the temperature. By combining all these characteristic values and applying the concentration app, it is possible to determine the concentration of substances in a liquid mixture.

Concentration measurement

The measuring device calculates the concentration of the liquid from the measured speed of sound, temperature and acoustic density.

Temperature measurement

A temperature sensor measures the temperature of the liquid. Due to the location of the sensor and the good thermal conduction, the sensor also reliably detects fast changes in temperature. The measuring device displays the temperature as a separate measured variable, and also uses the temperature measured variable to calculate the concentration of the liquid.

Measuring system

The measuring device consists of a mobile transmitter and a mobile sensor. The sensor sends the measured signals to the transmitter for analysis. Here, the measuring device uses concentration apps, which are individually tailored to the measurement task and encoded to work only with the serial number of a specific transmitter.

The measuring device is configured via the "Teqwave Mobile Viewer" operating tool. In addition, the operating tool enables the reading and graphic representation of the measured values.

The following components are included in the standard delivery package:

- Sensor
- Transmitter
- Carrying case for the proper storage and transportation of the measuring device
- Connecting cable
- USB cable
- USB charger
- Printed copy of the Operating Instructions in the form of a Quick Start Guide
- Operating Instructions on a CD-ROM
- At least one concentration app and operating tool on a CD-ROM

Mobile transmitter

 <p style="text-align: right; font-size: small;">A0035724</p>	<p>Materials:</p> <ul style="list-style-type: none"> ■ Transmitter housing: ABS plastic (acrylonitrile-butadiene-styrene copolymers) ■ Shockproof sealing: TPE plastic (thermoplastic elastomer) ■ Window material: glass plate <p>Operation and configuration:</p> <ul style="list-style-type: none"> ■ Operation via the graphic local display with a touch screen and membrane keypad ■ Configuration via the "Teqwave Mobile Viewer" operating tool supplied
--	---

Mobile sensor

 <p style="text-align: right; font-size: small;">A0035725</p>	<ul style="list-style-type: none"> ■ Materials: stainless steel, 1.4571 (V4A) ■ Insertion length: 180 mm (7")
--	---

Concentration apps and measurement points

A concentration app contains specific configurations for the measurement of a certain liquid and, along with the measured sensor signals, is used as the basis for calculating the concentration. Endress+Hauser provides a separate concentration app for every type of fluid.

A list of the available concentration apps is provided in the Applicator. If you require a concentration app that is not available in the standard settings, Endress+Hauser requires a sample of the fluid to create the concentration app. Every transmitter can use a maximum of 50 concentration apps.

To be able to use a concentration app on the measuring device, the user must first save the desired concentration app in a measurement point using the operating tool. The measurement point can then be loaded to the measuring device. It is possible to use the same concentration app for multiple measurement points.

Concentration apps are individually encoded to work only with the serial number of a specific transmitter. The transmitter in service uses the serial number saved in the .mf2, .lmp or .lmf file to check whether the concentration app has been specifically configured for use with this transmitter. If this is not the case, it is not possible to add the concentration app.

Operating tool

The "Teqwave Mobile Viewer" operating tool included in the delivery supports the following functions:

- Read, display, delete and export measured values saved in the transmitter
- Create report of saved measured values
- Read out and create report of results of functional tests
- Configure the operating language of the transmitter
- Add, delete and group measurement points
- Create new measurement points
- Create and save device configurations (Configuration manager)

Security

IT security

We only provide a warranty if the measuring device is installed and used as described in the Operating Instructions. The measuring device is equipped with security mechanisms to protect it against any inadvertent changes to the device settings.

IT security measures, which provide additional protection for the measuring device and device data transfer, must be implemented by the operators themselves in line with their security standards.

Input

Measured variables

Direct measured variable

- Temperature

Derived measured variable

- Concentration

Internal measured variable

 The internal measured variables are used to calculate the concentration. The measuring device does not show the measured variables on the local display.

- Speed of sound
- Density

Measuring ranges

Concentration	As per concentration app data sheet, maximum 0 to 100 %
Temperature	As per concentration app data sheet, maximum 0 to +100 °C (32 to +212 °F)
Speed of sound (internal measured variable)	600 to 2000 m/s
Density (internal measured variable)	0.7 to 1.5 g/cm ³

Power supply

Supply voltage

The measuring device is powered by a built-in battery. The battery is charged via a USB port.

Battery

Battery type	Lithium ion battery
Capacity	2300 mAh
Charging time	Approx. 2.5 h
Battery life	Approx. 8 h, at least 40 measured value recordings

USB port

Supply voltage	DC 5 V, 1 A, BCv1.2 standard
-----------------------	------------------------------

USB charger

Connection	USB socket Type A, as per BCv1.2 standard
Supply voltage	5 V
Charging current	1 A
Overload protection	Yes
Short-circuit proof	Yes
Power	6 W
Charge temperature	+10 to +40 °C (+34 to +104 °F)

Power consumption	Transmitter	Max. 2 W
--------------------------	--------------------	----------

Power supply failure The configuration and recorded data are retained in the device memory.

Electrical connection **Connections and transmitter connecting cable**

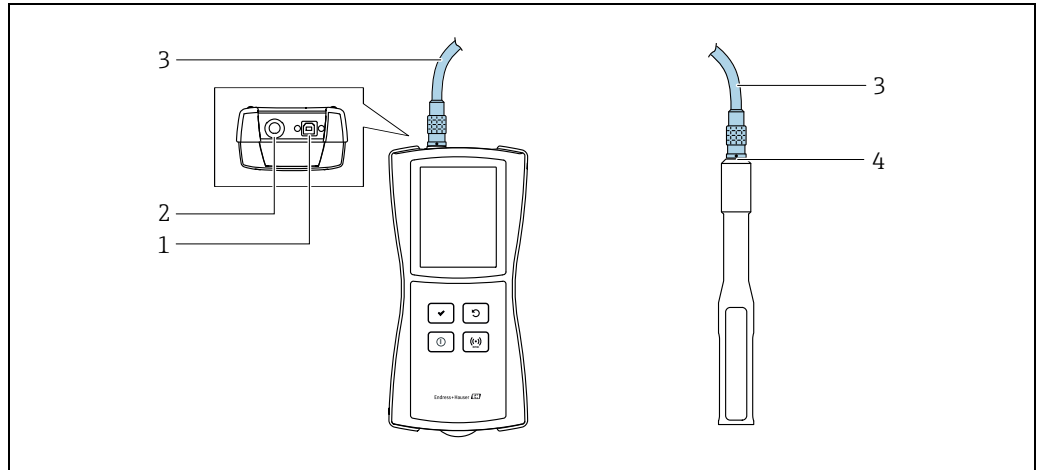

Connections and measuring device connecting cable

- 1 USB interface for charging the battery (BCv1.2 standard) and for digital data transmission to the computer
- 2 Transmitter push-pull connection
- 3 Connecting cable
- 4 Sensor push-pull connection

Cable specification **Connecting cable between sensor and transmitter**

Only use the cable supplied

USB cable

Cable type	USB 2.0, Type A to Type B
Cable length	Max. 2 m (6.56 ft)
Approval	UL 2725

Performance characteristics

Max. measured error	Temperature	±0.5 K
	Speed of sound (internal measured variable)	±2 m/s
	Density (internal measured variable)	±5 kg/m ³

Accuracy **Accuracy of concentration measurement**

The measuring device can achieve an accuracy of up to 0.01%. The accuracy depends on the concentration app. The data sheet for the concentration app contains detailed accuracy information under the "Approximation error" section.

Measuring frequencies	Concentration	Single measurement, value displayed averaged over 10 seconds
	Temperature	Single measurement, value displayed averaged over 10 seconds

Response time

The response time for displaying the temperature depends on the transfer of heat from the fluid to the steel.

Influence of variations in the fluid temperature If the fluid temperature changes quickly ($>1.5\text{ °C/min}$), the measuring device uses the integrated diagnostic functions to display an error message during a measurement.

Influence of vibrations If the measurement is affected by mechanical or acoustic vibrations in the 0.8 to 2.0 MHz range, the measuring device uses the integrated diagnostic functions to display an error message during a measurement.

Influence of air bubbles Air bubbles and particles are disturbance factors when measuring with acoustic surface waves. The diagnostic functions integrated in the measuring device largely prevent an incorrect measurement result due to air bubbles or particles.

Environment**Ambient temperature range**

Sensor	0 to +100 °C (+32 to +212 °F)
Transmitter	0 to +40 °C (+32 to +104 °F)

Storage temperature

Sensor	-20 to +120 °C (-4 to +248 °F)
Transmitter	-20 to +60 °C (-4 to +140 °F)

Degree of protection

Sensor	IP 68 (with cable plugged in)
Transmitter	IP 65

Electromagnetic compatibility (EMC)

- As per IEC/EN 61326-1
- Complies with emission limit for industry as per EN 55011 (Class A)

For details, refer to the Declaration of Conformity.

Process

Medium temperature range 0 to +100 °C (+32 to +212 °F)

Flow velocity Max. 5 m/s (16.4 ft/s)

Mechanical construction

Dimensions

Transmitter

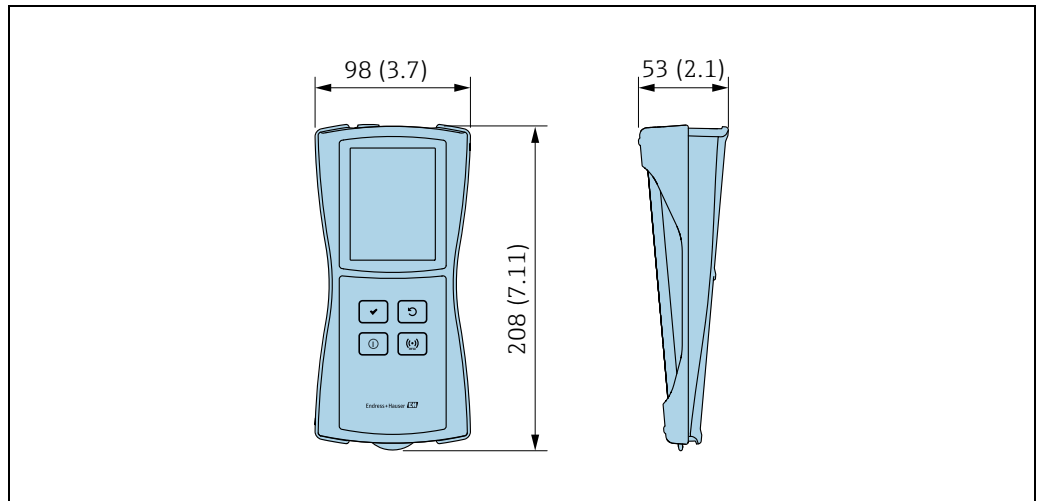

Transmitter dimensions. Dimensions in mm (in)

A0035721

Sensor

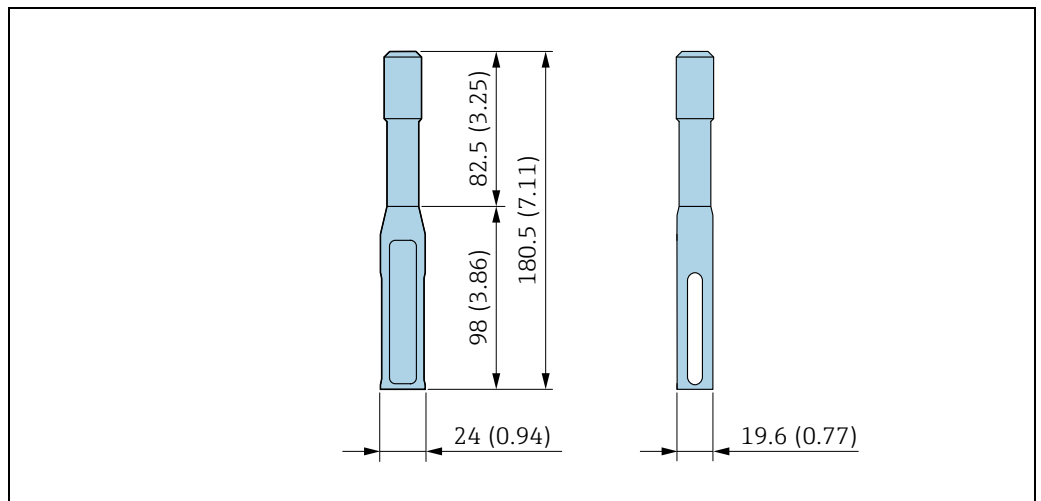

Sensor dimensions. Dimensions in mm (in)

A0035722

Weight

Transmitter	0.42 kg (0.93 lbs)
Sensor	0.3 kg (0.7 lbs)
Connecting cable	0.1 kg (0.2 lbs)

Materials

Transmitter

Housing	ABS plastic (acrylonitrile-butadiene-styrene copolymers)
Shockproof sealing	TPE plastic (thermoplastic elastomer)
Window material	Glass plate
Membrane keypad	<ul style="list-style-type: none"> ▪ Front membrane: Autotex V150 ▪ Bottom adhesive layer: DuploCOLL 101

USB connection	<ul style="list-style-type: none"> ▪ Socket: brass, nickel-plated ▪ Contact housing: polyetheretherketone (PEEK) ▪ Contacts: brass, chrome-plated
Push-pull connection	<ul style="list-style-type: none"> ▪ Socket: brass, nickel-plated ▪ Contact housing: polyetheretherketone (PEEK) ▪ Contacts: brass, chrome-plated

Sensor

Sensing element	Stainless steel, 1.4571 (V4A)
------------------------	-------------------------------

Connecting cable

Cable, external material	Polyurethane as per DIN EN 60811-2-1 (oil-resistant, halogen-free)
Connector	<ul style="list-style-type: none"> ▪ Socket: brass, nickel-plated ▪ Contact housing: polyetheretherketone (PEEK) ▪ Contacts: brass, chrome-plated

Operability

Local operation	<ul style="list-style-type: none"> ▪ Operation via touch screen and membrane keypad.
Operating tool	<ul style="list-style-type: none"> ▪ Operation via "Teqwave Mobile Viewer" Windows Desktop operating tool.
Reliable operation	<ul style="list-style-type: none"> ▪ If the power supply fails, data saved in the device and device configurations are retained.
Languages	<p>Can be operated in the following languages:</p> <ul style="list-style-type: none"> ▪ Via local operation (transmitter) English, German, French, Spanish, Italian ▪ Via operating tool English, German, French, Spanish, Italian

Certificates and approvals

CE mark	<p>The measuring system meets the legal requirements of the EU Directives. Endress+Hauser confirms that the device has been successfully tested with the enclosed Declaration of Conformity and by applying the CE mark.</p>
C-tick symbol	<p>The measuring system meets the EMC requirements of the "Australian Communications and Media Authority (ACMA)".</p>
Other standards and guidelines	<ul style="list-style-type: none"> ▪ EN 60529 Degrees of protection provided by enclosures (IP code) ▪ EN 61010-1 Safety requirements for electrical equipment for measurement, control and laboratory use - general requirements ▪ IEC/EN 61326-1 Electromagnetic compatibility (EMC requirements) ▪ RoHS and EN 50581 Restriction of hazardous substances in electric and electronic devices.

Ordering information

Detailed ordering information is available:

- In the Product Configurator on the Endress+Hauser website: www.endress.com → Select country → Instruments → Select device → Product page function: Configure this product
- From your Endress+Hauser Sales Center: www.endress.com/worldwide



Product Configurator - the tool for customized product configuration

- Up-to-the-minute configuration data
- Depending on the device: direct input of information specific to measuring point, such as measuring range or operating language
- Automatic verification of exclusion criteria
- Automatic creation of the order code and its breakdown in PDF or Excel output format

Accessories

Various accessories are available for the measuring device, and can be ordered with the device or at a later stage from Endress+Hauser. The Endress+Hauser Sales Center can provide detailed information on the relevant order code. The product page on the Endress+Hauser website www.endress.com also contains additional information on the order code.

Device-specific accessories

Accessories	Description
Connecting cable between sensor and transmitter	Order code for "Cable, sensor connection" (order number: XPD0047)
Concentration app	Data record for integrating new fluids into the measuring device. The concentration apps are available on the CD-ROM. A list of the available concentration apps and measuring ranges is provided in the Applicator. If you require a concentration app that is not already listed in the Applicator, Endress+Hauser requires a sample of the fluid to create the concentration app. Concentration apps must first be imported into the operating tool before they can be added from the tool to the measuring device as a measurement point. Endress+Hauser provides the concentration app in .mf2 or .lmf format. Every transmitter can use a maximum of 50 concentration apps. (Order number: DK9500)

Service-specific accessories

Accessories	Description
Applicator	Software for selecting and sizing Endress+Hauser measuring devices: <ul style="list-style-type: none"> ▪ Calculation of all the data needed to identify the optimum measuring device ▪ Graphic representation of the calculation results Administration, documentation and access to all project-related data and parameters throughout the entire life cycle of a project and information about the concentration apps that are available. Applicator is available: <ul style="list-style-type: none"> ▪ Via the Internet: https://portal.endress.com/webapp/applicator ▪ On CD-ROM for installation on local computer

Accessories	Description
W@M	<p>Life cycle management for your plant.</p> <p>W@M provides support with a wide range of software applications over the entire process: from planning and procurement to the installation, commissioning and operation of the measuring devices. All the relevant device information, such as the device status, spare parts and device-specific documentation, is available for every device over the entire life cycle.</p> <p>The application already contains the data of the Endress+Hauser devices. Endress+Hauser also takes care of maintaining and updating the data records.</p> <p>W@M is available:</p> <ul style="list-style-type: none"> ▪ Via the Internet: www.endress.com/lifecyclemanagement ▪ On CD-ROM for installation on local computer

Documentation

For an overview of the scope of the associated documentation, refer to the following:

- *W@M Device Viewer*: enter the serial number from the nameplate (www.endress.com/deviceviewer).
- *Endress+Hauser Operations App*: enter the serial number from the nameplate or scan the 2-D matrix code (QR code) on the nameplate.

Standard documentation

Document type	Documentation code
Operating Instructions	BA01824D
Special Documentation	SD02144D
Special Documentation	SD02145DA2

Registered trademarks

Applicator®

Registered or registration-pending trademarks of the Endress+Hauser Group

Autotex®

Registered trademark of MacDermid Autotype Limited, Wantage, UK

DuploCOLL®

Registered trademark of Lohmann GmbH, Neuwied, Germany

Microsoft®

Registered trademark of the Microsoft Corporation, Redmond, Washington, USA

www.addresses.endress.com
